

Wheel Shafts / Grooved Wheels / Caster Holders

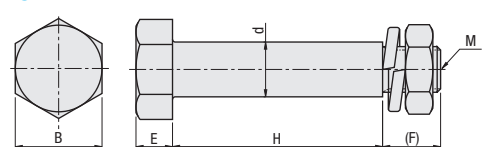

RoHS 10

KCRB



Component	Material	Surface Treatment
Shaft	SWCH	Trivalent Chromate
Nut (1 pc.)	JIS Class 3	
Spring Washer (1 pc.)	JIS B1251	

Part Number Type	No.	d	H	B	(F)	M	E	Unit Price
	75	10	38.3	17	10	8	7	
	100	12	46	19	12.7	10	8	
	130	20	55.9	30	19.3	14	13	
	150		60		17.3			

Ordering Example **Part Number**
KCRB130

Grooved Wheels



RoHS 10

V Groove Type
RVAB

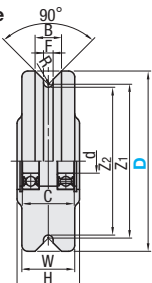

U Groove Type
RVAU

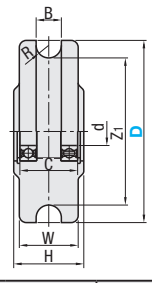

* Bearing Accuracy: JIS B 1514 Class 0
 ⚠ Bearings (2 pcs.) are press-fit.

Type		Body Material	Retaining Ring
V Groove	U Groove		
RVAB	RVAU	MC Nylon <small>Electrically Conductive MC Nylon</small>	Spring Steel

Groove Shape	Part Number Type	D	Wheel Material	d	R	Groove Depth		F	H	W	B	C	Bearing (2 pcs.)	Allowable Load (N)	Mass (g)	Unit Price	
						Z ₁	Z ₂									M (MC Nylon)	D (Electrically Conductive MC Nylon)
V Groove	RVAB	75	M (MC Nylon) D (Electrically Conductive MC Nylon)	10	2.5	59	55	5	36	32	16	29.3	6200ZZ	3530	210		
		100		83		79	38		34	17	31	6201ZZ	5099			360	
		130		109	104	50	42	21	41.2	6004ZZ	8238	740					
		150		128	123	52	44	22	43.2	6204ZZ	9807	870					
U Groove	RVAU	75	M (MC Nylon) D (Electrically Conductive MC Nylon)	10	8	59	-	-	36	32	16	29.3	6200ZZ	3530	210		
		100		8.5		83	-		-	38	34	17	31			6201ZZ	5099
		130		10.5	109	-	-	50	42	21	41.2	6004ZZ	8238	740			
		150		11	128	-	-	52	44	22	43.2	6204ZZ	9807	870			

Ordering Example **Part Number** - **Wheel Material**
RVAB75 - M

⚠ MC nylon stands for monomer cast nylon MonoCast®. MonoCast® is a registered trademark of Nippon Polypenco Ltd.

Caster Holders

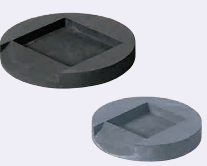

Type	Material	Hardness
CMHU	EPDM (Gray)	Shore A80
CMHD	Electrically Conductive Rubber (Black)	

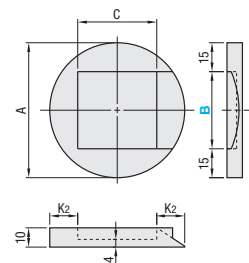

ex Example

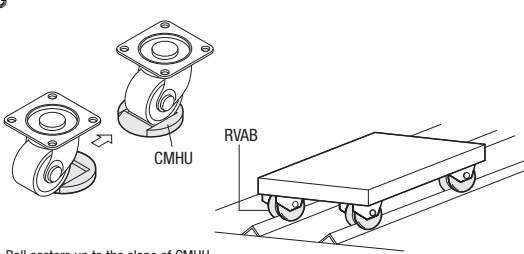

Roll casters up to the slope of CMHU to a stopped position.

Part Number Type	B	A	C	K ₂	Allowable Load (N)	Applicable Caster Wheel Width (Reference)	Mass (g)	Unit Price	
								CMHU	CMHD
CMHU CMHD (Electrically Conductive Rubber)	30	60	33	13.5	8000	28	30		
	40							38	35
	50							48	45

Ordering Example **Part Number**
CMHU50