

Similar Product Comparison Point

RoHS: Not Compliant, Standard for Running Test: Internal Standard Based on GB (for details, see P.1063)

Similar Products Page P.1066

**Swivel**



Type	Main Body		Wheel	Bearing	
	M Material	S Surface Treatment	M Material (Color)	Swiveling Part	Wheel
C-CTFJ	SPPC	Zinc Plating	Polypropylene (White)	Incorporated	None

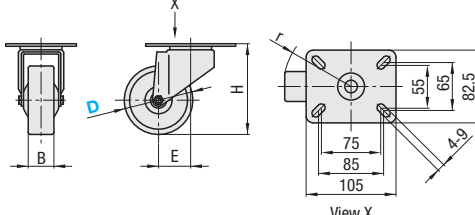

View X

Part Number		Wheel Material	H	B	E	r	Allowable Load (N)	Mass (g)	Unit Price
Type	D								
C-CTFJ	80	P (Polypropylene)	106	35	37.5	77.5	600	608	
	100		40		700		727		
	125		47		109.5		900	861	

**Swivel with Stopper**



Type	Main Body		Wheel	Bearing	
	M Material	S Surface Treatment	M Material (Color)	Swiveling Part	Wheel
C-CTFS	SPPC	Zinc Plating	Polypropylene (White)	Incorporated	None

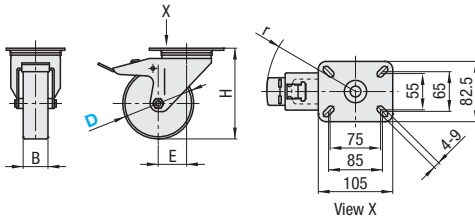

View X

Part Number		Wheel Material	H	B	E	r	Allowable Load (N)	Mass (g)	Unit Price
Type	D								
C-CTFS	80	P (Polypropylene)	106	35	37.5	125	600	770	
	100		40		700		828		
	125		47		127		900	976	

Ordering Example **Part Number** - **Wheel Material**  
**C-CTFJ80** - **P**