

# Cutters / Replacement Cutter Blades / Deburring Tools / Replacement Blades

**Cutters**

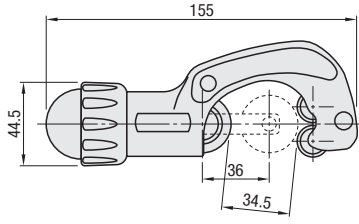

**PFCAT  
PFCATS**





Reinforced aluminum pipe frames and factory frames cannot be cut with this cutter.

Part Number	Applicable Frame	Mass (g)	Unit Price 1~9 pcs.	Volume Discount Rate 10~20
<b>PFCAT</b>	Extruded Aluminum Pipe Frame / Plastic Coated Pipe Frame	350		
<b>PFCATS</b>	Stainless Steel Pipe Frame	356		

**Caution**

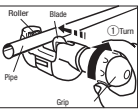
- If the cutter is used to cut unintended objects or used for purposes than the original, the cutter may be damaged or accidents may result.
- Be sure to check the cutter before use. If something is not right, do not use until it is repaired or replaced.
- Do not touch the blade during operation. Accidents or injury may result.
- Be careful of falling while carrying or operating.
- If the cutter becomes wet, be sure to wipe it dry. If water gets into the bearing, rust will prevent the bearing from functioning.

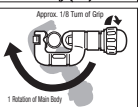
**How to Use**

- Rotate the grip and place the pipe between the cutter blade and the rollers. Be sure that the pipe protrudes more than the width of the rollers.
- Turn the grip further 1/4 rotation in the arrow direction in the diagram after the blade contacts the pipe, then rotate the pipe once to cut along the circumference.
- Then turn the grip slowly (approx. 1/8 turn per each body rotation) to cut gradually deeper and turn the main body to completely cut the pipe. \*If the cutting speed is too fast, it may cause pipe deformation, or shorten the blade's service life.

**Replacement Cutter Blades**



**PFCATH**  
(For Plastic Coated and Extruded Aluminum Pipe Frame)

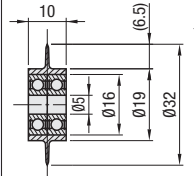

**PFCATHS**  
(For Stainless Steel Pipe Frame)

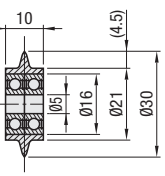

Accessory: Retaining Ring E Type 1 pc.

Part Number	Mass (g)	Unit Price 1~9 pc(s).	Volume Discount Rate 10~20
<b>PFCATH</b> (For Plastic Coated and Extruded Aluminum Pipe Frame)	19		
<b>PFCATHS</b> (For Stainless Steel Pipe Frame)	25		

For orders larger than indicated quantity, please check with WOS.  
How to Replace Replacement Blades: Remove the retaining ring E type of the cutter body, then pull installation pin for replacement.

**Ordering Example**

**Part Number**  
**PFCAT  
PFCATH**

**Deburring Tools / Replacement Blades**



**M-NG1000-F** (Deburring Tool: PFREMH-BS1010x1 pc.)  
**M-NG1000-S** (Deburring Tool: PFREMH-BS1018x1 pc.)  
**PFREMH-BS1010** (Replacement Blades, 10 pcs./pack)  
**PFREMH-BS2010** (Replacement Blades, 10 pcs./pack)  
**PFREMH-BS1018** (Replacement Blades, 10 pcs./pack)



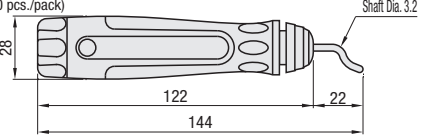

Material: Handle: Plastic + Rubber

**Deburring Tool**

Part Number	Mass (g)	Unit Price 1 ~ 9 pc(s).	Volume Discount Rate 10~30
<b>M-NG1000-F</b>	31		
<b>M-NG1000-S</b>	31		

**Ordering Example**

**Part Number**  
**M-NG1000-F  
PFREMH-BS1010**

**CAUTION**

Use for purposes other than deburring may cause damages or accidents.  
Be sure to check the deburring tool before use. If something is not right, do not use until it is repaired or replaced.  
Do not touch the blade during operation. Accidents or injury may result.

- The P/N PEREM has been changed to M-NG1000-F. The handle shape is slightly different but the functionality is the same.

**Replacement Blades**

Part Number	Unit Price* 1 ~ 9 pc(s).	Volume Discount Rate 10~30
<b>PFREMH</b>		
<b>BS1010</b>	For milling steel and aluminum. One sided blade used in clockwise rotation Black	
<b>BS2010</b>	For cast iron, brass and plastic. Double sided blade used in both directions Silver	
<b>BS1018</b>	For hard-cutting material such as stainless steel. One sided blade used in clockwise rotation Silver	

**How to Use**

- Hold the grip and apply the blade to the inside of the frame.
- Turn at least one full turn while keeping the blade in the direction of the pipe.

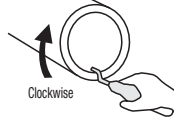

\* One set contains 10 pieces. For orders larger than indicated quantity, please check with WOS.