

Pipe Frame / Factory Frame Standard Units

Hand Truck



PFUB
(Pipe Frame)

FFUB
(Factory Frame)

W, D, H and T dimensions show the outer dimensions (end to end of the metal joint). For details, see Example of Metal Joint Calculation on P912 and How to Calculate Pipe Dimension on P879.

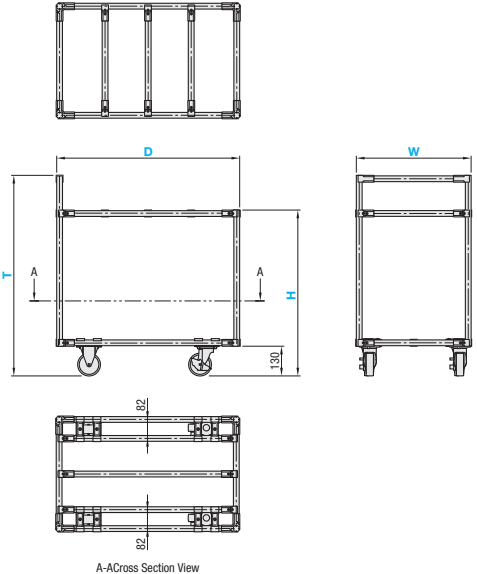

A-A Cross Section View

Customer assembly required.
With these pipe frame units, the number of the components is determined just by specifying the component types and each dimension. The unit can be completed just by assembling the components.

RoHS10

Part Number		W	D	H	T
Type	Frame / Color	1mm Increment	1mm Increment	1mm Increment	1mm Increment
PFUB (Pipe Frame)	W (White)	400~1000	600~1200	400~1200	700~1400
	V (Ivory)				
	S (Dark Gray)				
FFUB (Factory Frame)					

T ≥ H + 50 Please note the hand truck may become unstable depending on its size.

For frame types and colors, refer to P880, 881.

Ordering Example

Part Number	-	W	-	D	-	H	-	T
PFUBV	-	W600	-	D800	-	H750	-	T1000
FFUB	-	W650	-	D1000	-	H600	-	T800

Part Number		W	Unit Price 1 ~ 20 pc(s).		
Type	Frame / Color		D		
PFUB (Pipe Frame)	W (White)	400~600	600~800	801~1000	1001~1200
	V (Ivory)	601~800			
	S (Dark Gray)	801~1000			
FFUB (Factory Frame)		400~600			
		601~800			
		801~1000			

Alterations

Part Number	-	W	-	D	-	H	-	T	-	(AWF, ADF)
PFUBS	-	W800	-	D1000	-	H600	-	T750	-	AWF1-ADF2

Alteration	Code	Spec.	Alteration	Code	Spec.
Adds Joints for Upper Tier Pipe Frames	AWF	Adds Joints for Upper Tier Pipe Frames. ■ Components List • PFUB <input type="checkbox"/> ① PFS28-Color-(W-103) 1 pc. ② PBLSN1 2 pcs. • FFUB <input type="checkbox"/> ① FFA28-(W-110) 1 pc. ② FFB1 2 pcs. Ordering Code 1 pc. → AWF1 2 pcs. → AWF2	Adds Joints for Lower Tier Pipe Frames	ADF	Adds Joints for Lower Tier Pipe Frames. ■ Components List • PFUB <input type="checkbox"/> ① PFS28-Color-(D-103) 1 pc. ② PBLSN1 2 pcs. • FFUB <input type="checkbox"/> ① FFA28-(D-110) 1 pc. ② FFB1 2 pcs. Ordering Code 1 pc. → ADF1 2 pcs. → ADF2