

# Bushings for Locating Pins - High Hardness Stainless Steel

## Straight

For products uncovered by the e-Catalog Standards, see P.131.

Features: This product is much lower than, and can be delivered more quickly than the existing products.



RoHS10

| Type |      |      | Material                      | Hardness |
|------|------|------|-------------------------------|----------|
| Dp6  | Dm6  | Dh7  |                               |          |
| JBK  | JBKM | JBKS | High Hardness Stainless Steel | 35HRC~   |

$6.3 / (0.8 / \sqrt{\quad})$   
 Insertion Guide D  $\begin{matrix} -0.03 \\ -0.05 \end{matrix}$  1~3  
 $0.05 / \sqrt{\quad}$   
 $0 / -0.05$   
 $\text{A}$   
 $\text{A}$   
 $\text{A}$

| D  | p6               | m6               | h7          |
|----|------------------|------------------|-------------|
| 5  | +0.020<br>+0.012 | +0.012<br>+0.004 | 0<br>-0.012 |
| 7  | +0.024<br>+0.015 | +0.015<br>+0.006 | 0<br>-0.015 |
| 12 | +0.029<br>+0.018 | +0.018<br>+0.007 | 0<br>-0.018 |

### Straight

| Part Number                        |    | P                |                  | L   | R | Unit Price | Volume Discount Rate |            |             |
|------------------------------------|----|------------------|------------------|-----|---|------------|----------------------|------------|-------------|
| Type                               | D  | 0.1mm Increments | 0.1mm Increments |     |   |            | 1 ~ 19 pc(s).        | 20~49 pcs. | 50~100 pcs. |
| JBK (p6)<br>JBKM (m6)<br>JBKS (h7) | 5  | 2.0~3.0          | 5.0~10.0         | 0.5 |   |            |                      |            |             |
|                                    | 7  | 2.0~5.0          |                  |     |   |            |                      |            |             |
|                                    | 8  | 3.0~6.0          | 5.0~15.0         |     |   |            |                      |            |             |
|                                    | 10 | 4.0~8.0          | 5.0~20.0         |     |   |            |                      |            |             |
|                                    | 12 | 6.0~10.0         | 5.0~30.0         |     |   |            |                      |            |             |
|                                    | 14 | 6.0~10.0         |                  |     |   |            |                      |            |             |
|                                    | 15 | 8.0~12.5         | 5.0~40.0         |     |   |            |                      |            |             |

Ordering Example

|             |    |   |     |        |
|-------------|----|---|-----|--------|
| Part Number | P  |   | L   |        |
| Type        | D  | - | -   | L      |
| JBKM        | 8  | - | 5.9 | - 12.0 |
| JBKS        | 10 | - | 8.0 | - 20.0 |

Alterations

|             |    |   |     |        |                   |
|-------------|----|---|-----|--------|-------------------|
| Part Number | P  |   | L   |        | (FC, RS, RN, CRN) |
| Type        | D  | - | -   | L      |                   |
| JBKM        | 7  | - | 3.2 | - 10.0 | - FC              |
| JBKS        | 12 | - | 8.0 | - 25.0 | - CRN             |

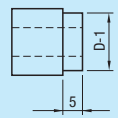
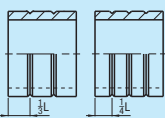
| Alterations  | Code | Spec.  |
|--|------|--|
| Groove (for Adhesive Reservoir)<br>                                 | FC   | Adds an adhesive reservoir groove.<br>• $D \geq P+3$ : Applicable only when a wall of 1.5mm or thicker is remaining.<br>• Applicable only when $L \geq 10$ .   |
| Adhesive Groove Machining<br>When $L \leq 13.0$ When $L > 13.0$<br> | RS   | Adds adhesive grooves.<br>• Number of O.D. Grooves<br>• When $L \leq 13.0$ → Adds two grooves.<br>• When $L > 13.0$ → Adds three grooves.<br>Ordering Code RS<br>• When $D \leq 13$ , $D - P \geq 3$ .<br>When $D \geq 14$ , $D - P \geq 4$ .<br>• Not applicable to $L < 9.0$ . |

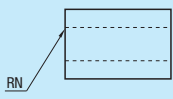
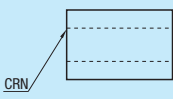
| Alterations   | Code | Spec.  |
|---|------|--|
| Radius R C Chamfered<br>   | RN   | Adds C Chamfering (0.5 or less) to R.                  |
| Radius R Square Corner<br> | CRN  | Replaces R with square corner.<br>• Edge may be burred |