

RoHS 10

Type	Material	Surface Treatment
C-BUFN	S45C	Black Oxide

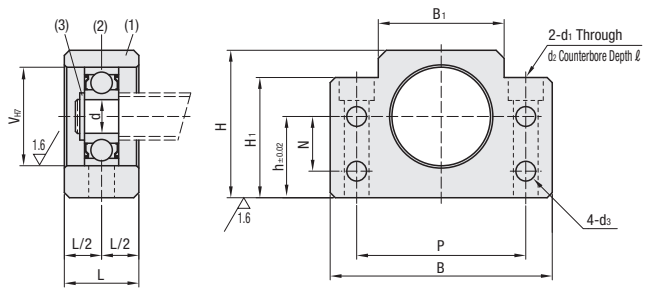

Component Details

Number	Part Name	Qty.
(1)	Housing	1
(2)	Overseas-made radial bearing	1
(3)	Retaining Ring (STWN)	1

Part Number		d	L	B	H	h	B ₁	H ₁	P	N	V	d ₁	d ₂	d ₃	ℓ	Bearing Part Number	Retaining Ring	C-BUFN Unit Price
C-BUFN	10	8		60	39	22	34			15	22				5	B608ZZ	STWN8	
	12	10	20		43	25	35	32.5	46		26	6.6	11	5.5	1.5	B6000ZZ	STWN10	
	15	15		70	48	28	40	38	54	18	32				6.5	B6002ZZ	STWN15	
	20	20	26	88	60	34	52	50	70	28	42	9	14	6.6	8.5	B6004ZZ	STWN20	
	25	25	30	106	80	48	64	70	85	33	52	11	17.5	9	11	B6205ZZ	STWN25	

Ordering Example **Part Number**
C-BUFN15 (Support side, separate item)

- For details of Bearings, Included Collars and Bearing Nuts in addition to mounting interface accuracies of Support Units, see **P.777**.
- Ball Screw Compatibility Chart **P.774**
- * Store Accessories with care since they are required when assembling.
- No.15, 20 and 25 cannot be used with MISUMI ball screws. For the applicable ball screws manufactured by the other companies, see **P.776**, "Ball Screw / Support Unit Mapping Table - Ball Screw Shaft Diameters: Ø20, Ø28, Ø30, Ø32 and Ø36."

SET part overview For customers using in conjunction with fixed side and support side MISUMI recommends a SET, which allows the fixed side and support side to be ordered as one set.
 5% price reduction when ordering in SETs



Fixed Side



Support Side

<SET parts>

SET Part Number	SET parts	
	Fixed Side Part Number	Support Side Part Number
C-BSFW10-SET	C-BSFW10	C-BUFN10
C-BSFW10S-SET	C-BSFW10S	C-BUFN10
C-BSFW12-SET	C-BSFW12	C-BUFN12
C-BSFW15-SET	C-BSFW15	C-BUFN15
C-BSFW20-SET	C-BSFW20	C-BUFN20
C-BSFW25-SET	C-BSFW25	C-BUFN25