

RoHS10

Type	Material	Surface Treatment
C-BUN	S45C	Black Oxide

d=6-8

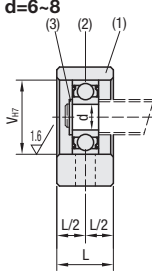

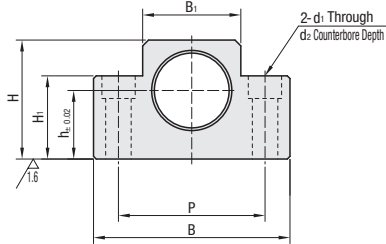

d=10-25

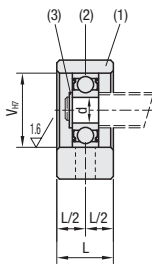

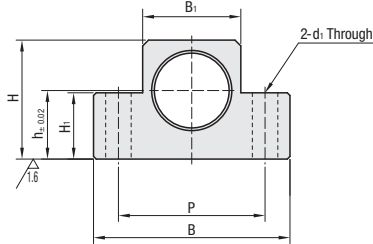

Component Details

Number	Part Name	Qty.
(1)	Housing	1
(2)	Overseas-made radial bearing	1
(3)	Retaining Ring (STWN)	1

Part Number																C-BUN	
Type	No.	d	L	B	H	h	B ₁	H ₁	P	V	d ₁	d ₂	ℓ	Bearing	Retaining Ring	Unit Price	
C-BUN	6	6	12	42	25	13	18	20	30	17	5.5	9.5	11	B606ZZ	STWN6		
	8		14	52	32	17	25	26	38	6.6	11	11					
	10	20	8	70	43	25	36	24	52	22	9	-	-	B608ZZ	STWN8		
	12		10	80	49	30	41	25	60	32				B6000ZZ	STWN10		
	15		15	95	58	30	56	25	75	47				B6002ZZ	STWN15		
	20		20	105	68	35	66	25	85	52				B6204ZZ	STWN20		
25	25	30	105	68	35	66	25	85	52	11	B6205ZZ	STWN25					

* Take care in combining No.20 with Ball Screw BSSZ(K)2510, BSSR(K)2510, BSST2510 or BSBR(K)2510 or in combining No.15 with Ball Screw BSBR(K)2010. The ball screw nut may come in contact with the bottom surfaces.

Ordering Example

Part Number
C-BUN15 (Support side, separate item)

SET part overview

For customers using in conjunction with fixed side and support side MISUMI recommends a SET, which allows the fixed side and support side to be ordered as one set. 5% price reduction when ordering in SETs

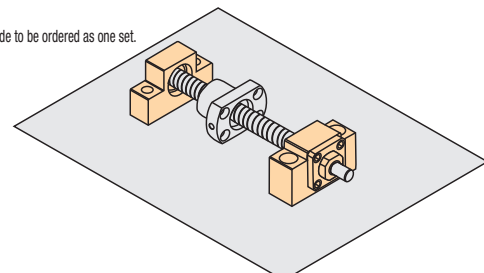



Fixed Side



Support Side

<SET parts>

SET Part Number	SET parts	
	Fixed Side Part Number	Support Side Part Number
C-BSW6-SET	C-BSW6	C-BUN6
C-BSW8S-SET	C-BSW8S	C-BUN8
C-BSW8-SET	C-BSW8	C-BUN8
C-BSW10S-SET	C-BSW10S	C-BUN10
C-BSW10-SET	C-BSW10	C-BUN10
C-BSW12-SET	C-BSW12	C-BUN12
C-BSW15S-SET	C-BSW15S	C-BUN15
C-BSW15-SET	C-BSW15	C-BUN15
C-BSW20-SET	C-BSW20	C-BUN20
C-BSW25-SET	C-BSW25	C-BUN25