

Welded Steel Stands

Plate Type

■ **Features:** Height and mounting hole pitch can be specified in 1mm increment.

Type	Material	Surface Treatment
YSSP	SS400	-
YSBP		Black Oxide
YSMP		Electroless Nickel Plating
YSFP	SUS304	-

✓ ($\frac{6.3}{\sqrt{\quad}}$)

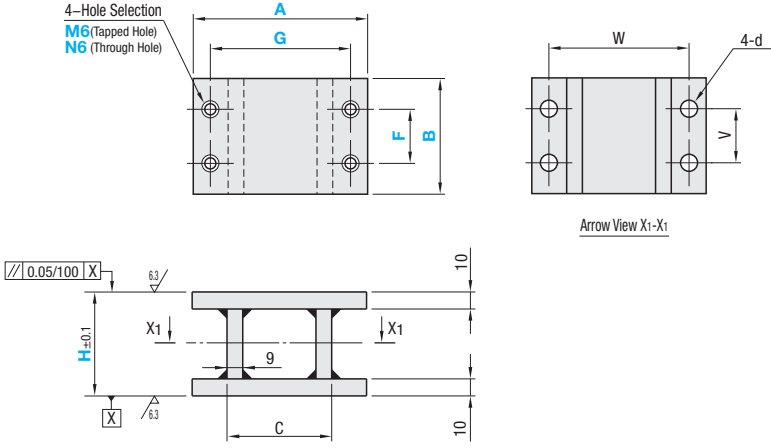
4-Hole Selection
M6 (Tapped Hole)
N6 (Through Hole)

Arrow View X1-X1

$\sqrt[0.05/100]{X}$ $\frac{6.3}{\sqrt{\quad}}$ $H_{-0.1}$ X_1 X_2 9 10 10 10

RoHS10 ⊗ The SS400 products have shot blasted area in $\sqrt{\quad}$.

Part Number Type	A	B	1mm Increment			Hole Type	C	V	W	d
			H	F	G					
YSSP (No Surface Treatment)	100	50	50~200	$15 \leq F \leq B - 20$	80	M6 (Tapped Hole) N6 (Ø6.5 Through Hole)	50	30	80	6.5
		60						40		
		70						50		
		80						60		
		100						80		
	120	50			90~100		60	30	100	9
		60						40		
		70						50		
		80						60		
		100						80		
	150	50			105~130		75	30	130	11
		60						40		
70		50								
80		60								
100		80								
200	50	130~180	100	30	170	11				
	60			40						
	70			50						
	80			60						
	100			70						
	120			90						
	200			170						



Ordering
Example

Part Number - B - H - F - G - Hole Type
 YSSP100 - B100 - H150 - F75 - G80 - M6
 YSSP200 - B150 - H200 - F100 - G150 - N6