

Stage Maintenance Parts

Micrometer Head

■ **Features:** Micrometer head which enables fine adjustment can be ordered separately. Economical MISUMI original products are also available.

■ Micrometer Head



MCLN1

(Stroke ±3.25mm)

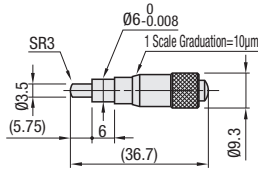

MCLN2

(Stroke ±3.25mm)

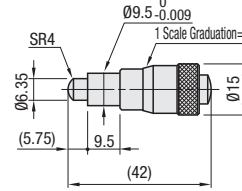

MCLN3 (w/ Nut)

(Stroke ±3.25mm)

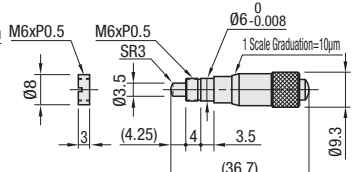

MCLN4

(Stroke ±3.25mm)

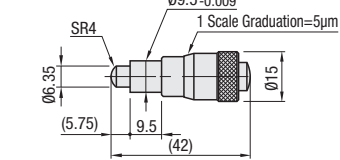

MCLN6 (w/ Nut)

(Stroke ±6.5mm)

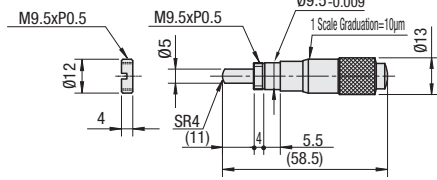

MCLN12 (w/ Nut)

(Stroke ±12.5mm)

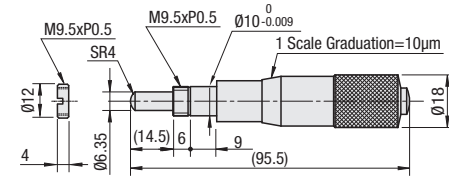

MCLN83 (w/ Nut)

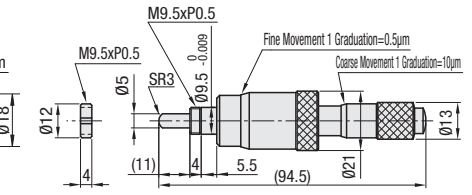

MCLN84 (w/ Nut)

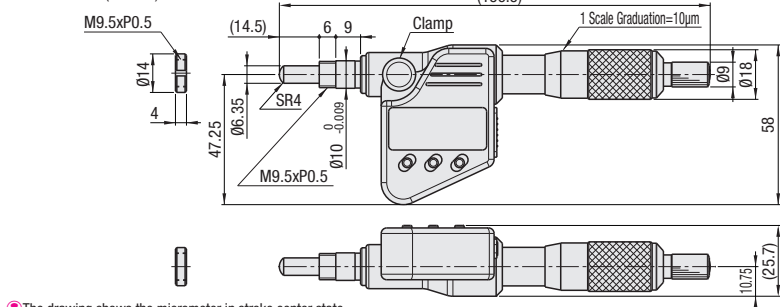

⚠ The drawing shows the micrometer in stroke center state.

⚠ Micrometer has a bolt/nut system, so the total length doesn't change.

■ Material Spindle: SKS, Handle: SUM, Nut/Thread: Low Cadmium Brass

▲ Accessory: Dedicated Wrench (W/ Nut Type only)

■ Standard Micrometer Head (MISUMI Original)



RoHS 10

MCMH6

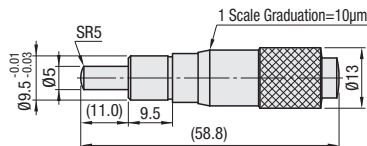

Type	Spindle		Main Body	
	Material	Material	Material	Surface Treatment
MCMH	SUS416	SUM43		Trivalent Chromate

Part Number Type	No.	Stroke (mm)	Minimum Graduation (mm)	Travel Distance per Rotation (mm)	Weight (kg)	Unit Price
	2					
	3	0.005	0.25	0.03		
	4					
	6	±6.5	0.01	0.5	0.09	
	12					
	83	Coarse Feed ±6.5 Fine Feed 0.2	Coarse Feed 0.01 Fine Feed 0.0005	0.5	0.10	
	84	±12.5	0.001	0.5	0.235	
MCMH	6	±6.5	0.01	0.5	0.03	



Ordering Example

Part Number

MCLN6

MCMH6