

[Simplified Adjustments] Angle Adjusting Units

■ **Features:** Tight clamping can be achieved by adjusting the rotation direction by the handle and holding the upper and lower surfaces by using screws. Friction effect prevents angle misalignment when clamped.

■ Rotary Stages, Simplified Angle Adjusting Units

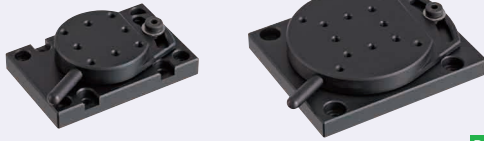

RoHS 10

■ Friction Effect

A plastic washer inserted at the top-and-bottom-plate connecting portion causes appropriate friction, preventing angle misalignment by overtightening of the clamp screw.

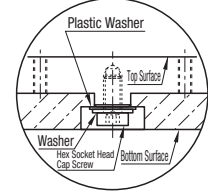

XKRC40

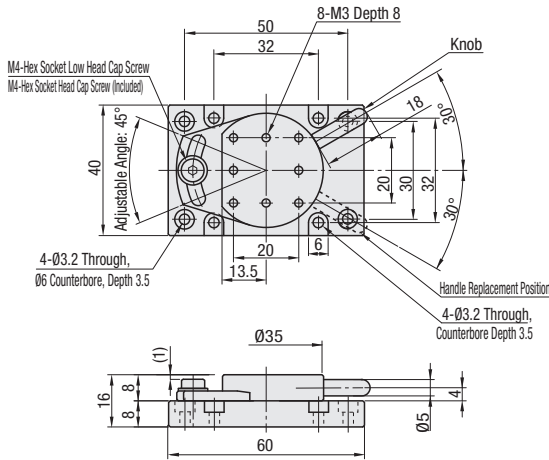

XKRC60

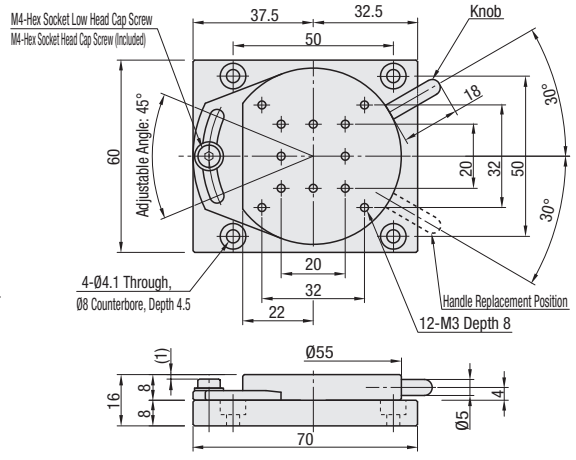

- Ⓜ Top and bottom plates are ground fit, thus the accuracy of the mating plane may change the sliding resistance.
- Ⓢ The adjustment handle is removable, and two handle mounting holes are provided.
- ⓐ A Hex Socket Head Cap Screw (M4) is included as a clamp bolt enabling clamping by a wrench.

- Ⓜ Material: Aluminum Alloy
- Ⓢ Surface Treatment: Black Anodize
- ⓐ Accessory: Hex Socket Head Cap Screw RSCB4-10, 1 pc.

Part Number Type	Stage Surface No.	Travel Distance (mm)	Load Capacity (N) Horizontal	Weight (kg)	Unit Price
XKRC	40	Ø35	±22.5°	9.8	0.07
	60	Ø55		14.7	0.15



Ordering Example

Part Number
XKRC60

[Combination Examples of Adjustment Units]

Simplified Adjustment Units	XKRC40	Page	XKRC60	Page
	XKCS30	1895	XKCS30	1895
XKDSP40	1964	XKDSP60	1964	
XKEMA40	1964	XKEMA60	1964	
High Precision Stages Standard Stages	XFES40	1896	XFES60	1896
	XCRS40	1917	XCRS60	1917
	XZLNG40	1992	XZLNG60	1992
	ZFES40	1961	ZFES60	1961
	ZCRS40	1967	ZCRS60	1967
	ZLFG40	1972	ZLFG60	1972
	ZLPG40	1973	ZLPG60	1973
	ZLTG40	1974	ZLTG60	1974



Example

■ Position Adjustment of Inspection Camera at Painting

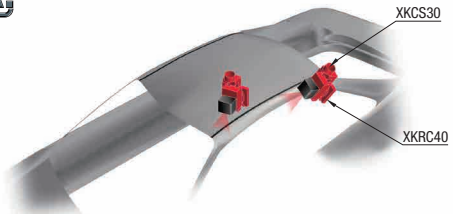

Example

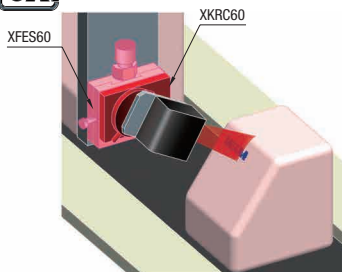

■ Position Adjustment of Print Inspection Instrument

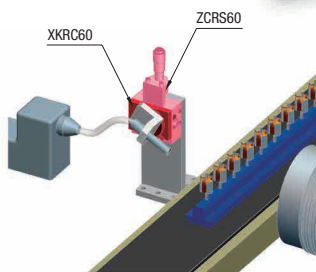

■ Neutralization by Air for Electronic Components

■ Syringe Angle Adjustment

