

[High Precision] X-Axis Dovetail Slide, Rack & Pinion

Rectangular, Steel, High Load Capacity

■ **Features:** XWGSR stages are made of steel, with higher horizontal load capacities and impact resistance compared to the XWG Series (P1904).

■ X-Axis, High Load Capacity

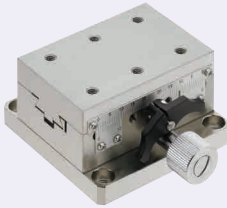

RoHS 10

XWGSR40

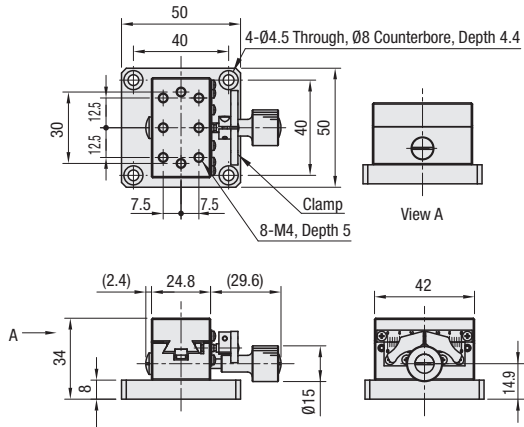

XWGSR60

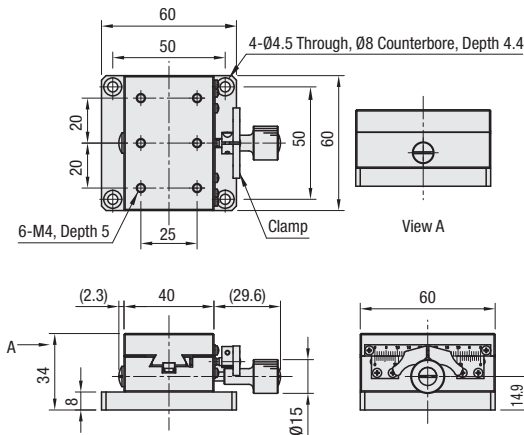

XWGSR90

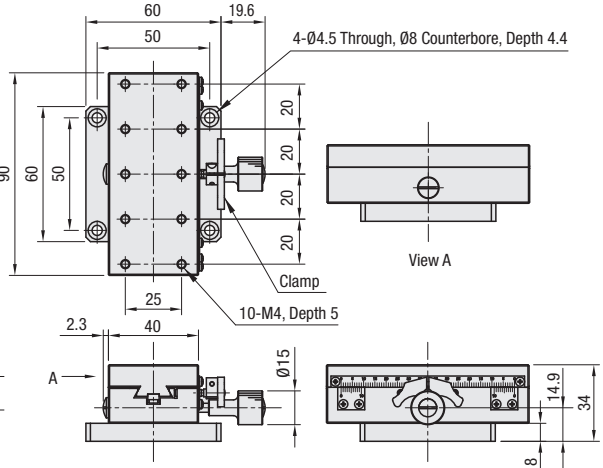

■ Material: S45C
 ■ Surface Treatment: Electroless Nickel Plating

Part Number	Stage Surface	Travel Distance	Travel per Rotation	Horizontal Load Capacity	Moment Load Capacity (N·m)			Travel Accuracy (µm)		Parallelism	Weight (kg)	Accessory (4 pcs.)	Unit Price
					Pitching	Yawing	Rolling	Straightness	Motion Parallelism				
XWGSR	40	24.8x40	±12	18	98	5.0	3.3	2.6	30	40	50µm	SCB4-10	
	60	40x60	±21		196	15.0	7.8	10.4					
	90	40x90	±35		294	27.5	16.5	28.6					

⊕ Resolution (Vernier Scale Indication): 0.1 mm/division

⊕ Knob Cover HDCVR15 (Sold Separately): Ø15 knobs can be increased in diameter by installing the cover. P2004



Ordering Example

Part Number
XWGSR40