

Toggle Clamps

Hold Down, Horizontal Long Handle (Flange Base)

1N=0.101972kgf

Hold Down, Horizontal Long Handle (Flange Base)



Part Number	MC01L-1
Body Material	SS400
Surface Treatment	Trivalent Chromate
Tightening Force (N)	264.6
Weight (g)	35
Arm Open-Close Angle	90°
Handle Open-Close Angle	73°
Accessory	* Nylon Bolt
Unit Price	

Hold Down, Horizontal Long Handle (Flange Base)

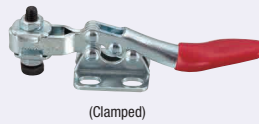

Part Number	MC01L-2
Body Material	SS400
Surface Treatment	Trivalent Chromate
Tightening Force (N)	264.6
Weight (g)	40
Arm Open-Close Angle	90°
Handle Open-Close Angle	73°
Accessory	* Nylon Bolt
Unit Price	

MC01L-1

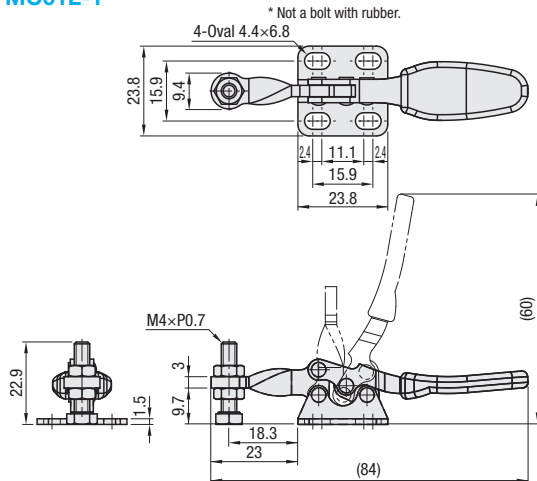

MC01L-2

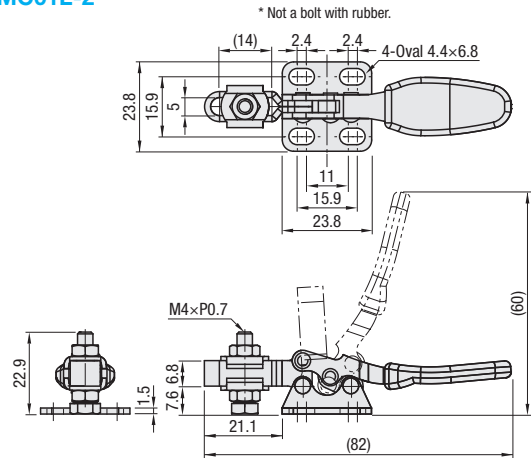

Hold Down, Horizontal Long Handle (Flange Base)



Part Number	MC01L-3
Body Material	SS400
Surface Treatment	Trivalent Chromate
Tightening Force (N)	882
Weight (g)	140
Arm Open-Close Angle	80°
Handle Open-Close Angle	73°
Accessory	Bolt with Rubber Material: NBR Hardness: Shore A70
Unit Price	

MC01L-3

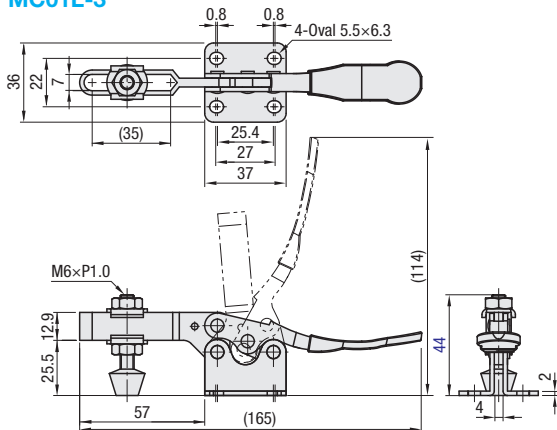

Example

Clamp for LCD Continuity Tests of Mobile Phones.

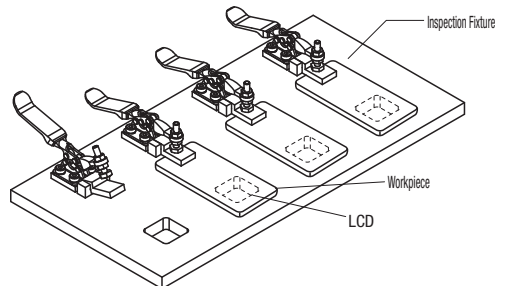

Long Handle Features (Comparison with Conventional Products)

■ Conventional Products

■ Long Handle

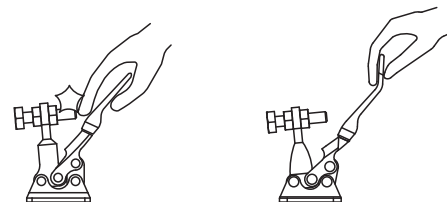

Ordering Example

Part Number
MC01L-1