

Indexing Plungers

Compact / Long

■ **Features:** Has shorter length by 2/3 compared to the general indexing plungers. Can be used in narrow space.

■ Compact



RoHS10

Type		Screw	Knob	Main Body			Pin	Spring
Returning	Rest Position			M Material	M Material	S Surface Treatment		
PMXSB	PMXYSB	Coarse Thread	Nylon 6	S45C	Black Oxide	Electroless Nickel Plating	SUS303	SUS304-WPB
PMXSM	PMXYSM							

Returning
PMXSB
PMXSM

Rest Position
PMXYSB
PMXYSM

• Features of the Returning Type and Rest Position Type
 ■ P:1779

Part Number		Pitch (Coarse)	D	D ₁	S	B	L	L ₁	SW	R	Load (N)		Unit Price				
Returning	Rest Position										M	min	max	PMXSB	PMXSM	PMXYSB	PMXYSM
PMXSB	PMXYSB	8	1.25	20	14.5	5	5	25	5	13	3	2.5	6.0				
PMXSM	PMXYSM	10	1.5	24	19	6	6	31	7	17	3.5	4.5	9.5				



Ordering Example

Part Number
PMXSB10

■ Construction Diagram

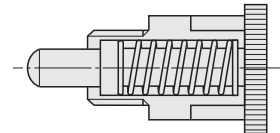

■ **Features:** Having longer mounting threads, the plunger can be mounted to a thick plate.

■ Long, Returning



RoHS10

Screw	Type	Knob			Main Body			Pin			Spring		(Lock Nut)								
		M Material	M Material	S Surface Treatment	M Material	H Hardness	S Surface Treatment	M Material	M Material	S Surface Treatment	M Material	S Surface Treatment									
Fine Thread	PXAL	A2017 (Black Anodize)	SUM22	Black Oxide	S45C	50~60HRC	Black Oxide	SUS631J1	-	-	-	-	-	-							
	PXKL														SS400	Black Oxide					
	SXPAL														SUS303	-	SUS440C	45HRC~	-	-	-
	SXPKL																				

⦿ For M=8 and 8L, the pin hardness is 40~45HRC.

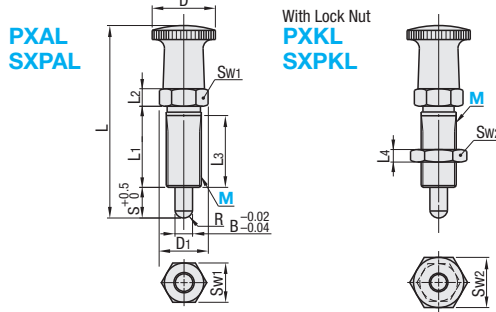

Mass (g)

M	PXAL SXPAL	PXKL SXPKL
8	13	18
10	22	29
12	35	45
16	78	98

Part Number		Pitch (Fine Thread)	D	D ₁	S	B	L	L ₁	L ₂	L ₃	L ₄	Sw ₁	Sw ₂	R	Load (N)		Unit Price			
Type	M														min.	max.	PXAL	PXKL	SXPAL	SXPKL
PXAL PXKL SXPAL SXPKL	8	1.0	15	11.5	4	4	46	22	5	20	4	10	13	2	3	9				
	8L				48															
	10	1.0	18	13.8	5	5	53	25	5	23	5	12	17	2.5	5	11.5				
	10L				56															
	12	1.5	21	16.2	6	6	64.5	30	6	27	6	14	19	3	6.5	14.5				
	12L				68.5															
	16	1.5	26	21.9	7	8	80	38	8	34.5	8	19	24	4	7.15	18				
	16L				85															

kgf=Nx0.101972



Ordering Example

Part Number
PXAL8
SXPKL16L