

Blocks for Shim Adjustment of Welding Fixtures / Shim Sets

Straight, L-Shaped

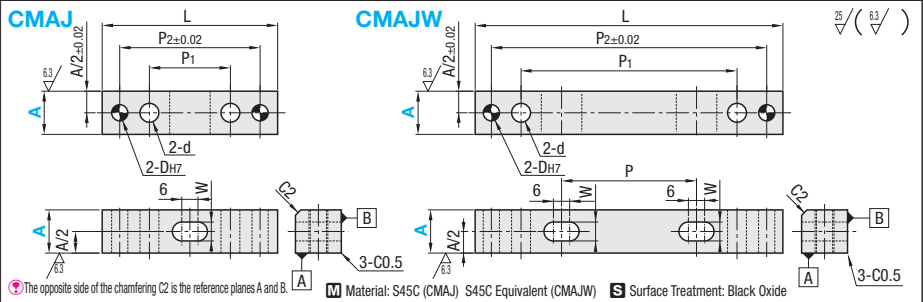

Part Number Type	A	L	D	d	P	P1	P2	W	Unit Price	Volume Discount Rate
									1 - 9 pc(s).	10 - 30 pcs.
CMAJ	16	65	6	7	-	30	52	7		
	20	75	8	9		40	62	9		
CMAJW	16	114	6	7	50	80	102	7		
	20	124	8	9		90	112	9		

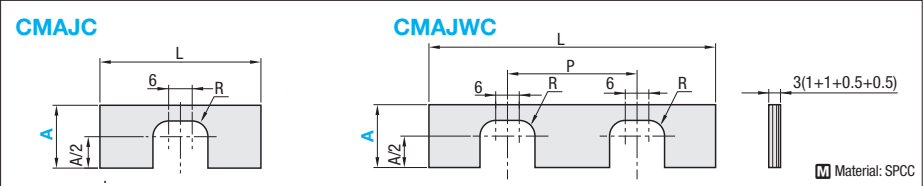

Part Number Type	A	L	R	P	Unit Price	Volume Discount Rate	Note	
					1 - 9 set(s)	10 - 30 sets	For orders larger than indicated quantity, please check with WOS.	
CMAJC	16	65	4	-				
	20	75	5					
CMAJWC	16	114	4	50				
	20	124	5					

This product is offered as a set of 2 pieces of 1mm and 0.5mm thickness.

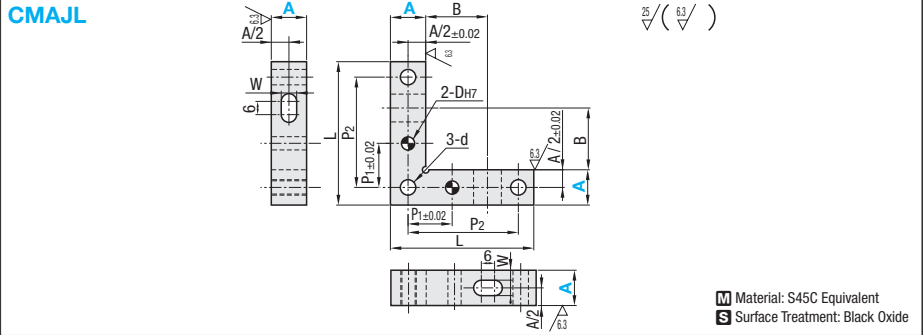

Part Number Type	A	L	D	d	B	P1	P2	W	Unit Price	Volume Discount Rate
									1 - 9 pc(s).	10 - 30 pcs.
CMAJL	16	65	6	7	28	20	50	7		
	20	100	8	9	53	40	80	9		

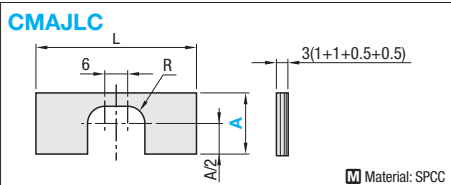

Part Number Type	A	L	R	Unit Price	Volume Discount Rate
				1 - 9 set(s)	10 - 30 sets
CMAJLC	16	42	4		
	20	54	5		

This product is offered as a set of 2 pieces of 1mm and 0.5mm thickness. For orders larger than indicated quantity, please check with WOS.

Ordering Example

Part Number
CMAJ16
CMAJC16
CMAJL16
CMAJLC20

