

Leveling Bolts / Lock Nuts

Standard, Thick Wrench Flats

Leveling Bolts Standard



RoHS 10

Type		M Material	S Surface Treatment
L Selectable	L Configurable		
LVB	LVFB	S45C	Black Oxide
LVBM	LVFBM	Equivalent	Electroless Nickel Plating
LVBS	LVFBS	SUS304	-

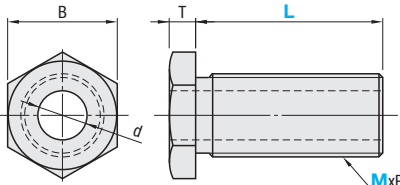

MxP



Example

How to Use

•LVB Leveling Screw: Loosen mounting screw first. LVB can then be turned to provide the adjustments to the base plate. Lock nuts (LVN) are used to prevent rotation.

*When the position of the base plate is decided, tighten the mounting screw again.

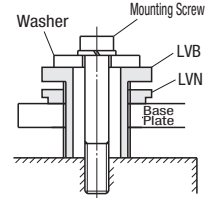

Part Number	L		d	MxPitch (Fine)	T	B	Applicable Screw	Unit Price															
	Type	M (Fine)						Selectable	Configurable 1mm Increment	LVB	LVBM	LVBS	LVFB	LVFBM	LVFBS								
(L Selectable)	(L Configurable)	8	5	10	15	20	25	30	5-50	3.5	8x0.75	4	13	M3	L=5-50	L=60-100	L=5-50	L=60-100					
		10	10	15	20	25	30	40	50	5.5	10x1.0	4	17	M4, 5									
		12	10	15	20	25	30	40	50	7	12x1.0	4	19	M6									
		16	15	20	25	30	40	50	60	80	9	16x1.5	5	22	M8								
		20		25	30	40	50	60	80	13	20x1.5	5	27	M10, 12									
		24		25	30	40	50	60	80	17	24x1.5	8	32	M16									
		30		30	40	50	80	100	25-120	23	30x1.5	8	36	M20									

Ordering Example

Part Number - L

LVB12 - 15

LVFB20 - 60

Leveling Bolts Thick Wrench Flats



RoHS 10

Type	M Material	S Surface Treatment
LLVBB	S45C	Black Oxide
LLVBM	Equivalent	Electroless Nickel Plating
LLVBS	SUS304	-

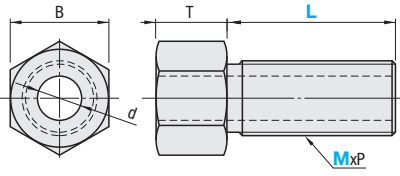

MxP



Example

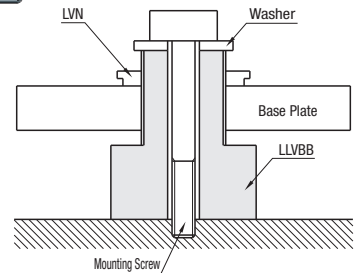

Features: A wrench can be readily used for tightening the screw for the thick T dimensioned parts.

Part Number	Type	M (Fine)	L 1mm Increment	d	MxPitch (Fine)	T	B	Applicable Screw	Unit Price		
									LLVBB	LLVBM	LLVBS
		8	9-35	3.5	8x0.75	13	13	M3			
		10	10-55	5.5	10x1.0	16	17	M4, 5			
		12	10-60	7	12x1.0	18	19	M6			
		16	15-70	9	16x1.5	20	22	M8			
		20	15-80	13	20x1.5	24	27	M10, 12			
		24	20-80	17	24x1.5	28	32	M16			
		30	25-80	23	30x1.5	30	36	M20			

Ordering Example

Part Number - L

LLVBM24 - 30

Lock Nuts

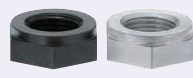

RoHS 10

Type	M Material	S Surface Treatment
LVN	S45C	Black Oxide
LVNM	Equivalent	Electroless Nickel Plating
LVNS	SUS304	-

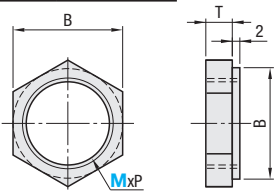

MxP

Part Number	Type	M (Fine)	MxPitch (Fine)	T	B	Unit Price		
						LVN	LVNM	LVNS
		8	8x0.75	4	13			
		10	10x1.0	4	17			
		12	12x1.0	4	19			
		16	16x1.5	5	22			
		20	20x1.5	5	27			
		24	24x1.5	8	32			
		30	30x1.5	8	36			

Ordering Example

Part Number

LVN20