

# Conveyor Hoppers

**Features:** It can be used to efficiently input bulk goods to conveyors. Width, length, and height are configurable.

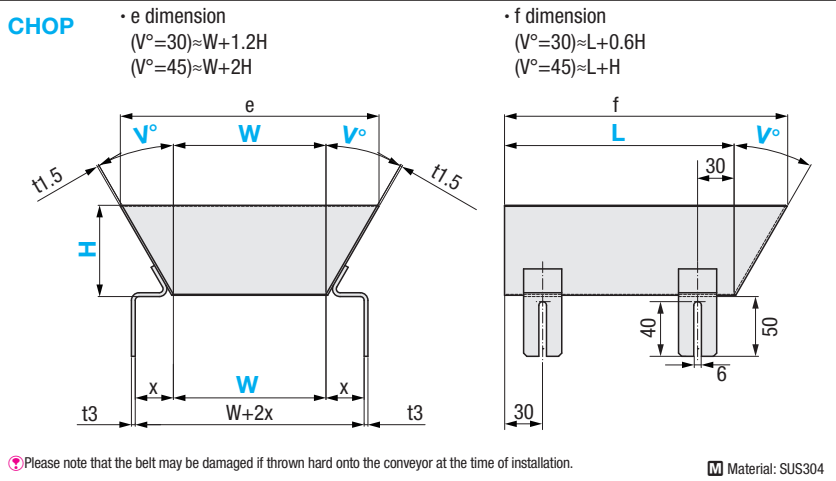
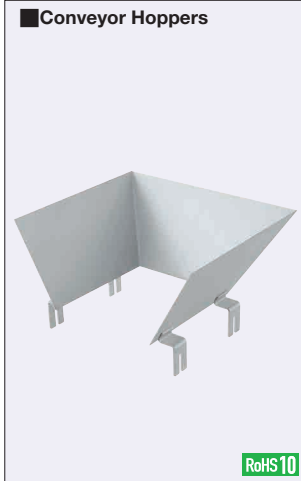

Part Number		Applicable Conveyor Type	L 10mm Increment	W 1mm Increment	H 10mm Increment	X
Type	V					
CHOP	30 45	A	100~500	25~500	50~300	20.5
		B				22.5
		C				27.5
		D				21.5

How to Select W Dimensions:  $W = B$  (Conveyor Belt Width) - 5

**List of Applicable MISUMI Conveyors**

Applicable Conveyor Type	Applicable Conveyors
A	CVGA, CVGB, CVGC, CVGD, CVMA, CVMB
B	CVGN, CVGP, CVGR, CVGW, CVSJA, CVLPA
C	SVKA, SVKB, SVKN, SVKR, CVSE, CVSF, CVSX, CVSY, CVSFA, CVSFB, CVSFC, CVSFD
D	CVSMA

Ordering Example: **Part Number** - **Applicable Conveyor Type** - **L** - **W** - **H**  
**CHOP30** - **A** - **100** - **100** - **80**

L	W	Unit Price					
		V					
		30			45		
		H					
		50~100	110~200	210~300	50~100	110~200	210~300
100~200	25~100						
	101~200						
	201~300						
	301~400						
210~300	401~500						
	25~100						
	101~200						
	201~300						
310~400	301~400						
	401~500						
	25~100						
	101~200						
410~500	201~300						
	301~400						
	401~500						
	25~100						

**Alterations**

Part Number - Conveyor Types - L - W - H - (EA)  
**CHOP30** - **A** - **100** - **100** - **80** - (EA)

**Alterations Code** **EA**

**Spec.** Ultrahigh Molecular Weight Polyethylene Attached  
 The ultrahigh molecular weight polyethylene seal is attached to the inner surface of the hopper so that the workpiece will move smoothly.

