

Transparent Covers for Conveyor

Dedicated web site <http://fa.misumi.jp/cvs/>

Conveyor selecting, component purchases, and easy search for maintenance parts are available.

Transparent Covers for Conveyor



RoHS 10

Type	Material	Grade	Color	Light Transmittance
CTCA	PET	Standard	Transparent	87%
CTCB			Smoke Brown	28%
CTCT		Antistatic	Transparent	77%

Components

No.	Product Name	Part Number	
①	Aluminum Extrusion	HFS5-2020	
②	PET Material (3mm thickness)	CTCA:PYA CTCB:PYBA CTCT:PYTA	
③	Extrusion End Cap	HFC5-2020-S	
④	Blind Joint Component	HMJ5	
⑤	Panel Clamp	HSCP3H-S	
⑥	Reversal Tabbed Bracket	Main Unit: HBLFSN5 Hex Socket Head Cap Screw: CBM5-10 Pre-Assembly Insertion Nut: HNTT5-5	
	⑦	Hinge	Main Unit: HHPST5 Hinge Nut: HHPNT5-2 Pre-Assembly Insertion Nut: HNTT5-5 Extra Low Hex Head Cap Screw: CBSA5-10
		⑧	Pull Handle
⑨	Conveyor Mounting Bracket		Main Unit: (Dedicated Part (Aluminum Alloy)) Hex Socket Flat Head Cap Screw: HFB5CM5-8
	⑩	Blind Bracket	G Only: HBLBS5

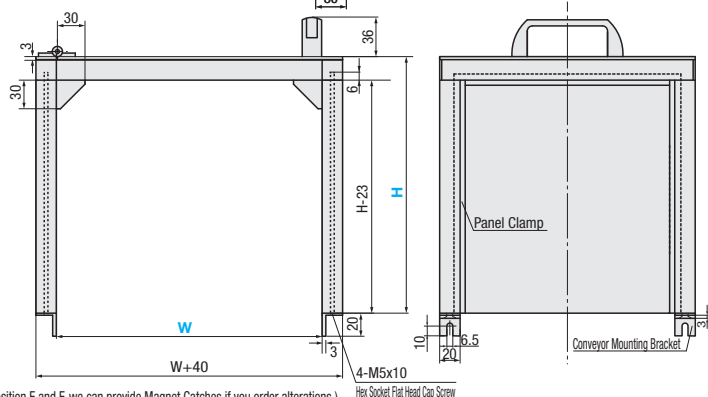
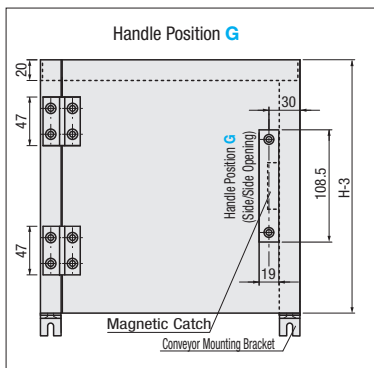
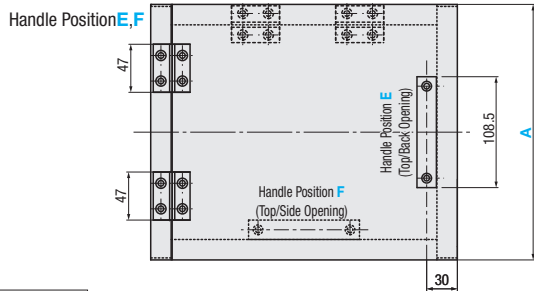

- Ⓜ When the handle position is G, Magnet Catches will be provided. (For the handle position E and F, we can provide Magnet Catches if you order alterations.)
- Ⓜ The panel without the handle will have a transparent cover (PET) in the aluminum extrusion slots (with Panel Clamp HSCP3H-S).
- Ⓜ Assembly will be required on your side. (The assembly instruction manual is included.)

Part Number	H	A	W	Unit Price		
				CTCA	CTCB	CTCT
Type	Handle Position	10mm Increment		1mm Increment		
CTCA (Transparent)	E (Top/Back Opening)	150~300	150~200	150~300		
			210~400	301~500		
CTCB (Smoke Brown)	F (Top/Side Opening)	150~200	150~300	150~300		
			210~400	301~500		
CTCT (Antistatic, Transparent)	G (Side/Side Opening)	310~500	150~200	150~300		
			210~400	301~500		
			150~300	150~300		
			210~400	301~500		
			410~550	150~300		
			210~400	301~500		
			410~550	150~300		
			210~400	301~500		
			410~550	150~300		
			210~400	301~500		



Ordering Example

Part Number - H - A - W
Type Handle Position
CTCA E - 200 - 150 - 300



Alterations



Part Number - H - A - W - (FCB, MGC, TK, TKL, TKR)

Type Handle Position
CTCA F - 200 - 150 - 300 - MGC
CTCT G - 300 - 300 - 200 - TKL

Alterations	Magnet Catches Included	Assembly and Shipping Services
Code	MGC	TK, TKL, TKR
Spec.	Magnet Catches (MGCC3) for an opening/closing window are included. Ⓜ Applicable to the handle position E and F only	We will fully assemble the product before shipping. Select TK for the handle position E and F, and select TKL (left) or TKR (right) for G.



Example

CTCAG

