

Nut Dimensions			
M	B ₁	(e)	T
M6	10	11.5	5
M8	13	15	6.5
M10	17	19.6	8

Type	Material			
	① Main Body	② Spacer	③ Main Ball	④ Sub Ball
BCHN	SUS304		SUS440C	(HRC55-)
BCHF				

Part Number	Type	D ₁	L ₁	H	M	L	d	B	ℓ	Allowable Load N (kgf)	Unit Price
12		1.5	6.5	6	15	5.56	3	3.5		41(4.2)	
16		2.5	9.5			8.73				55(5.6)	
19		3.5	11.5	8	20	10.32	4	5		62(6.3)	
25		5.3	14.7			15.87				343(35)	
31		6.3	18.7	10	25	19.05	5	6		412(42)	

Part Number	Type	D	D ₁	L ₁	H	t	P.C.D	a	d	Allowable Load N (kgf)	Unit Price
27		15	2.5	9.5	2	21	3.5	8.73	55(5.6)		
30		18	3.5	11.5	2	24	3.5	10.32	62(6.3)		
39		24	5.3	14.7	3	31.5	4.5	15.87	343(35)		
48		30	6.3	18.7	4	39	5.5	19.05	412(42)		

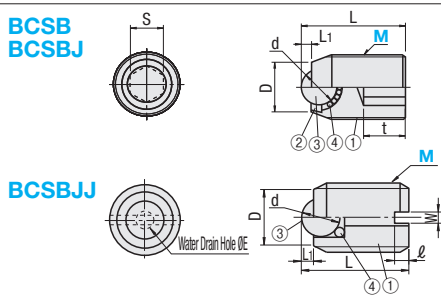

⚠ Size M8 main balls are swaged in place without a spacer (2).

Type	Material			
	① Main Body	② Spacer	③ Main Ball	④ Sub Ball
BCSB	SUSXM-7	SUS304	SUS440C	(HRC55-)
BCSBJ				
BCSBJJ	Polyacetal	-	Polyacetal Ball	SUS440C (HRC55-)

Part Number	Type	M	L	L ₁	D	d	S	t	Allowable Load N (kgf)		Unit Price
									BCSB	BCSBJ	
8		14	1.3	5	4.76	4	5		5(0.5)	1(0.1)	
10		16	1.2	7	4.76	5	6		14(1.4)	7(0.7)	
12		20	1.5	8	5.56	6	8		41(4.2)	27(2.8)	
16		25	2.5	12	8.73	8	10		55(5.6)	34(3.5)	
20		30	3.5	15	10.32	10	12		62(6.3)	55(5.6)	

Part Number	Type	M	L	L ₁	D	d	E	W	ℓ	Allowable Load N (kgf)	Unit Price
8		14	1.5	6	4.76	1.5	1.2	1.5		2(0.2)	
10		16	1.7	8	5.56	2.5	1.5	2		4(0.4)	
16		25	2.8	12	8.73	3	2	3		7(0.7)	
20		30	3.5	14	10.32	3.5	3	4		11(1.1)	

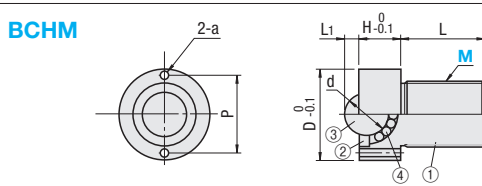

⚠ For tightening, wrenches for ball rollers are required. (Refer to Alteration BR)

Type	Material			
	① Main Body	② Spacer	③ Main Ball	④ Sub Ball
BCHM	SUS304	SUS304	SUS440C	(HRC55-)

Part Number	Type	M	L	L ₁	H	D	d	a	P	Allowable Load N (kgf)	Unit Price
10		12	2.5	10	18.5	8.73			2	15.4	55(5.6)
12		15	3.5	11	22	10.32				18.5	62(6.3)
16		20	5.3	15	27	15.87			2.5	24	343(35)
20		25	6.3	18	33	19.05				29.6	412(42)

ex Example

(Installation Examples)

① Set Screw ② Hex Head Stud Type ③ Press fit ④ Round Head Stud Type ⑤ With Plunger Press Fit ⑥ With Plunger Threaded



Part Number
BCHP18



Alterations Part Number - (BR)
BCHPT20 - BR

Alteration	Code	Spec.
Special Wrench Included	BR	Includes a special wrench. ⚠ For BCHPT and BCHM only.

Nominal	BCHPT Applicable (Nominal)	BCHM Applicable (M)	L	A	B	C	D	D ₁	P	a
10	16	For M10	25	8	19	3	18.5	10	15.4	
12	20	For M12	30	10	24	4	22	12	18.5	2
16	24	For M16	35	12	27	6	27	17	24	
20	-	For M20	40	14	30	7	33	20	29.6	2.5