

# FK Type Support Unit

## Round Type for Fixture



**RoHS COMPLIANT** **REACH**  
The new EU chemicals legislation



Please, download CAD DATA from [www.sungilfa.com](http://www.sungilfa.com)

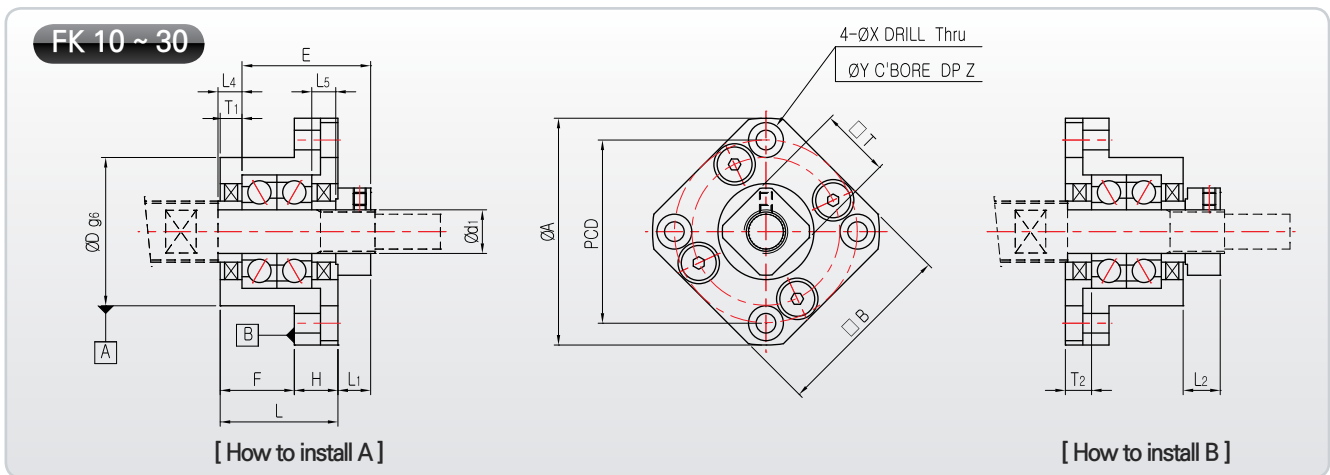
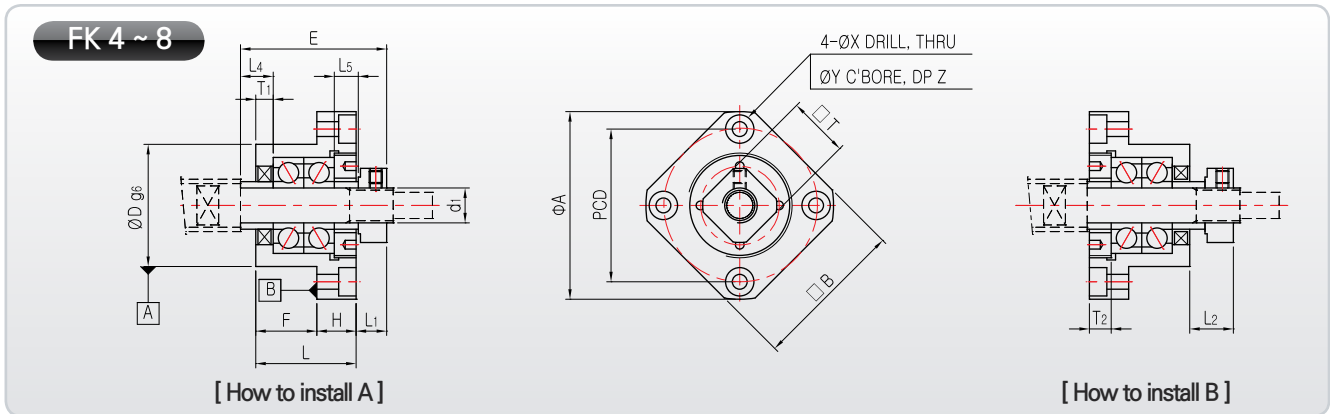

※ For the FK 30, when you install like 'B way', collar sizes must be changed, so please contact us.

### Note

1. The surfaces A and B are reference for installation. Please, use the accurate size spacer if adjusting height is necessary.
2. Do not disassemble the support unit since the preload of the bearing has already been adjusted.
3. Appropriate amount of grease is filled in the bearing of fixed-side support unit.
4. Please refer to page 66 about bearing type and characteristic according to Support Unit grade
5. Please refer to page 86 for fastening torque of the lock nut.

Unit : mm

Model No.	d <sub>1</sub>	L	H	F	E	D	A	PCD	□B	How to install A		How to install B		X	Y	Z	Collar Size		□T	Mass (g)
										L <sub>1</sub>	T <sub>1</sub>	L <sub>2</sub>	T <sub>2</sub>				L <sub>4</sub>	L <sub>5</sub>		
FK4 P5 / P0-C7	4	15	6	9	22	18	32	24	25	5.5	3/2	5.5/6.5	4/3	3.4	6	4	4.5/3.5	4.5/3.5	10	40
FK5 P5 / P0-C7	5	16.5	6	10.5	24	20	34	26	26	5.5/6.5	3.5	6	5/3	3.4	6/6.5	4	5.5/4.5	5.5/4.5	11	50
FK6	6	20	7	13	29	22	36	28	28	5.5	3.5	8.5	4.5	3.4	6.5	4	7	5	12	65
FK8	8	23	9	14	33.5	28	43	35	35	7	4	10	5	3.4	6.5	4	7.5	5.5	14	125
FK10	10	27	10	17	29.5	34	52	42	42	7.5	5	8.5	6	4.5	8	4	5.5	5.5	16	200
FK12	12	27	10	17	29.5	36	54	44	44	7.5	5	8.5	6	4.5	8	4	5.5	5.5	19	225
FK15	15	32	15	17	36	40	63	50	52	10	6	12	8	5.5	9.5	6	10	10	22	340
FK17	17	45	22	23	46	50	77	62	61	10	9	13	12	6.6	11	10	9	9	24	770
FK20	20	52	22	30	50	57	85	70	68	8	10	12	14	6.6	11	10	11	11	30	1065
FK25	25	57	27	30	60	63	98	80	79	13	10	20	17	9	15	13	15	15	35	1465
FK30	30	62	30	32	61	75	117	95	93	11	12	17	18	11	17.5	15	9	9	40	2300