

AF Type Support Unit

Square Type for Support



Please, download CAD DATA from www.sungilfa.com

AF 8 ~ 20

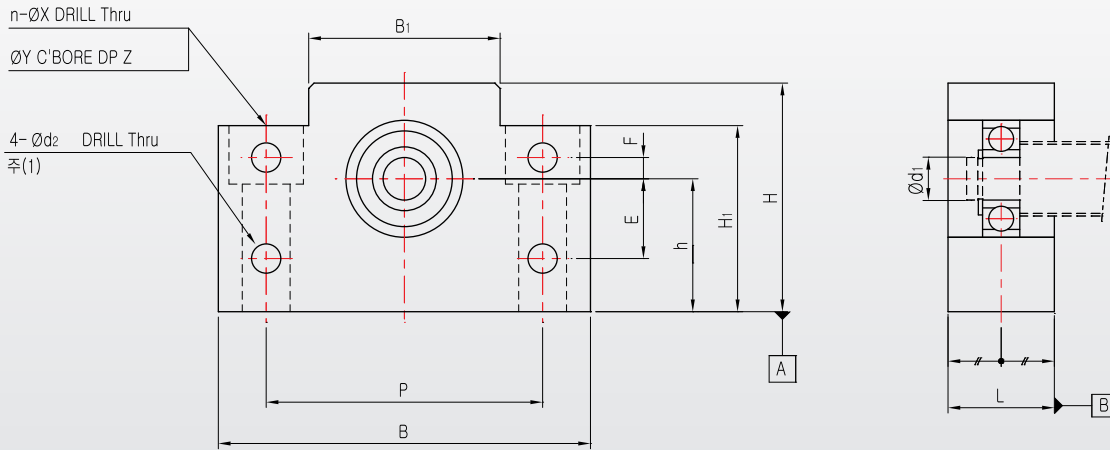

Remark (1) : AK 20 has no drilled hole at the annotated position

Note

1. The surfaces A and B are reference for installation. Please, use the accurate size spacer if adjusting height is necessary.



Unit : mm

Model No.	d ₁	L	B	H	h±0.02	B ₁	H ₁	E	F	P	d ₂	X	Y	Z	Mass (g)	Bearing	Snap Ring
AF8	6	15	52	32	17	25	26	10	4	38	5.5	6.6	11	12	130	606ZZ	C6
AF10	8	20	70	43	25	36	35	15	4	52	6.6	9	14	11	320	608ZZ	C8
AF12	10	20	70	43	25	36	35	15	4	52	6.6	9	14	11	300	6000ZZ	C10
AF15	15	20	80	50	30	41	40	15	4	60	6.6	9	14	11	370	6002ZZ	C15
AF20	20	26	95	58	30	56	45	-	-	75	-	11	17	15	660	6204ZZ	C20