

BF Type Support Unit

Square Type for Support

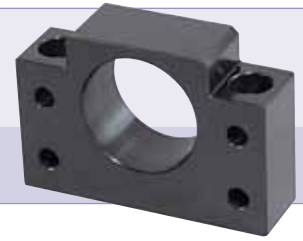

RoHS COMPLIANT **REACH**
The new EU chemicals legislation

Please, download CAD DATA from www.sungilfa.com

BF6~8

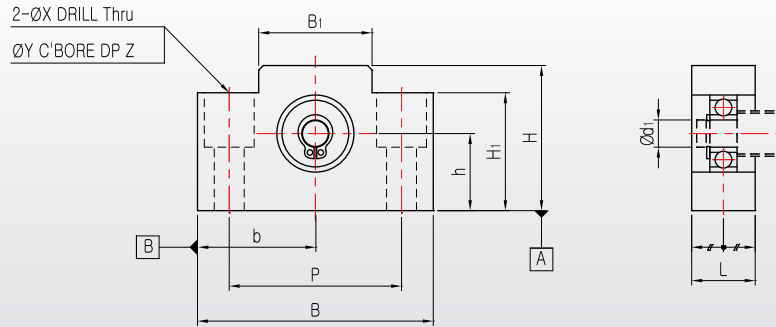

BF10~40

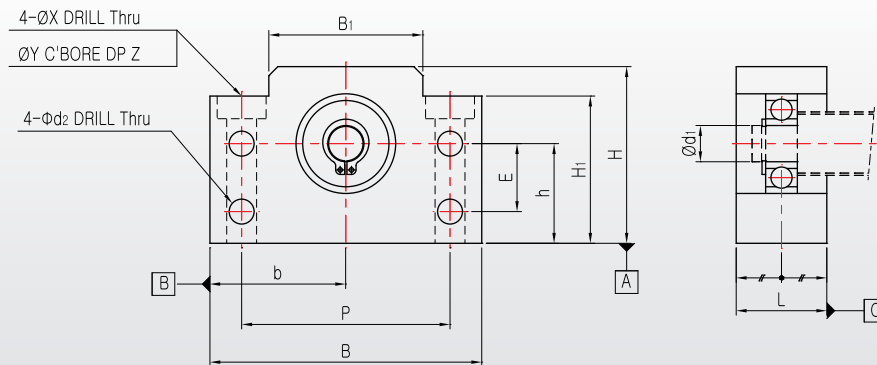

Note

1. The surfaces A and B are reference for installation. Please, use the accurate size spacer if adjusting height is necessary.



Unit : mm

Model No.	d ₁	L	B	H	b±0.02	h±0.02	B ₁	H ₁	E	P	d ₂	X	Y	Z	Mess(g)	Bearing	Snap Ring
BF6/8	6	14	52	32	26	17	25	26	-	38	-	6.6	11	12	120	606ZZ	C6
BF10	8	20	60	39	30	22	34	32.5	15	46	5.5	6.6	10.8	5	260	608ZZ	C8
BF12	10	20	60	43	30	25	34	35	18	46	5.5	6.6	10.8	6.5	270	6000ZZ	C10
BF15	15	20	70	48	35	28	40	38	18	54	5.5	6.6	10.8	6.5	310	6002ZZ	C15
BF17	17	23	86	64	43	39	50	55	28	68	6.6	9	14	8.5	680	6203ZZ	C17
BF20	20	26	88	60	44	34	52	50	22	70	6.6	9	14	8.5	710	6004ZZ	C20
BF25	25	30	106	80	53	48	64	70	33	85	9	11	17.5	11	1340	6205ZZ	C25
BF30	30	32	128	89	64	51	76	78	33	102	11	14	20	13	1880	6206ZZ	C30
BF35	35	32	140	96	70	52	88	79	35	114	11	14	20	13	2080	6207ZZ	C35
BF40	40	37	160	110	80	60	100	90	37	130	14	18	26	17.5	3100	6208ZZ	C40