

BK Type Support Unit

Square Type for Fixture

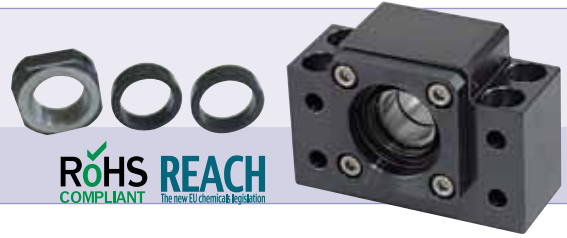

ROHS COMPLIANT REACH The new EU chemicals legislation

Please, download CAD DATA from www.sungilfa.com

BK 6 ~ 8

2-ØX DRILL Thru
ØY C'BORE DP Z

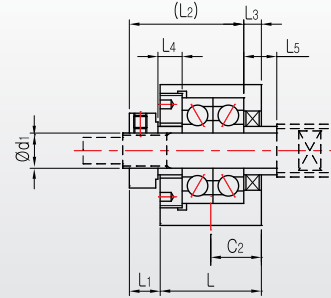
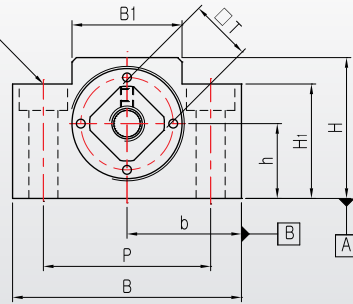

BK10~40

4-ØX DRILL Thru
ØY C'BORE DP Z
4-Ød2 DRILL Thru

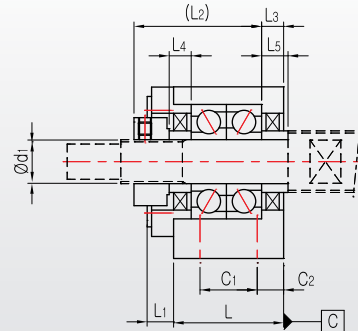
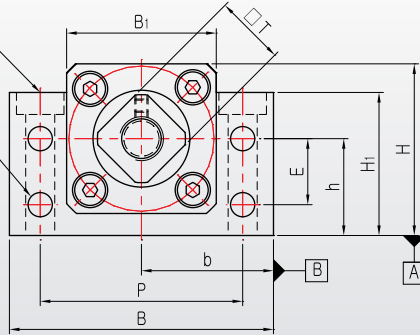

Note

1. The surfaces A and B are reference for installation. Please, use the accurate size spacer if adjusting height is necessary.
2. Do not disassemble the support unit since the preload of the bearing has already been adjusted.
3. Appropriate amount of grease is filled in the bearing of fixed-side support unit.
4. Please refer to page 66 about bearing type and characteristic according to Support Unit grade
5. Please refer to page 86 for fastening torque of the lock nut.

Unit : mm

Model No.	d ₁	L	L ₁	L ₂	L ₃	B	H	b±0.02	h±0.02	B ₁	H ₁	E	P	C ₁	C ₂	d ₂	X	Y	Z	Collar Size		□T	Mass (g)
																				L ₄	L ₅		
BK6	6	23	5	24	4	52	32	26	17	25	26	-	38	-	11.5	-	6.6	11	6	5	5	12	230
BK8	8	23	7	26	4	52	32	26	17	25	26	-	38	-	11.5	-	6.6	11	6	5.5	7.5	14	230
BK10	10	25	5	29	5	60	39	30	22	34	32.5	15	46	13	6	5.5	6.6	10.8	5	5	5	16	360
BK12	12	25	5	29	5	60	43	30	25	34	35	18	46	13	6	5.5	6.6	10.8	6	5	5	19	390
BK15	15	27	6	32	6	70	48	35	28	40	38	18	54	15	6	5.5	6.6	10.8	6	6	6	22	530
BK17	17	35	9	44	7	86	64	43	39	50	55	28	68	19	8	6.6	9	14	8.5	7	7	24	1270
BK20	20	35	8	43	8	88	60	44	34	52	50	22	70	19	8	6.6	9	14	8.5	8	8	30	1650
BK25	25	42	12	54	9	106	80	53	48	64	70	33	85	22	10	9	11	17.5	11	9	9	35	2310
BK30	30	45	14	61	9	128	89	64	51	76	78	33	102	23	11	11	14	20	13	9	9	40	3330
BK35	35	50	14	67	12	140	96	70	52	88	79	35	114	26	12	11	14	20	13	12	12	50	4380
BK40	40	61	18	76	15	160	110	80	60	100	90	37	130	33	14	14	18	26	17.5	15	15	50	6670