

SCJ Series Cross Joint Coupling

Please, download CAD DATA from www.sungilfa.com

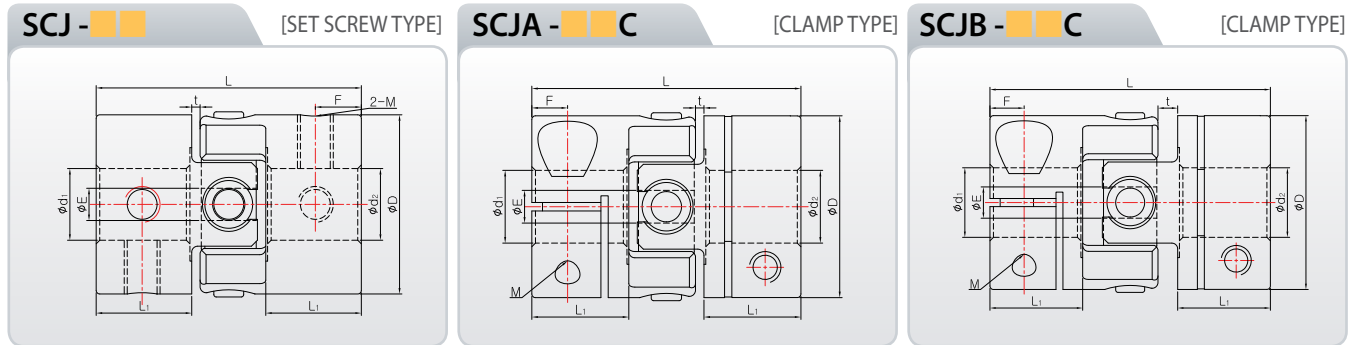

Dimensions & Performance

Product Number	Fastening Bolt M	Fastening Torque (N·m)	Max. RPM (min ⁻¹)	Max Torque (N·m)	Rated Torque (N·m)	Torsional Stiffness (N·m/rad)	Moment of Inertia (kg·m ²)	Mass (g)	Permissible Misalignment		
									Angle (°)	Parallel (mm)	End-Play (mm)
SCJA-15C	M2.6	1	21,000	0.5	0.25	220	3.3×10 ⁻⁷	9	1.5	0.3	0
SCJA-20C	M2.6	1	16,000	1	0.5	350	1.2×10 ⁻⁶	19	1.5	0.5	0
SCJA-25C	M3	1.7	12,000	2	1	800	3.3×10 ⁻⁶	34	1.5	0.5	0
SCJA-32C	M4	3.5	9,000	4	2	1,200	1.1×10 ⁻⁵	72	1.5	0.5	0
SCJA-40C	M5	8	7,000	10	5	1,900	3.2×10 ⁻⁵	140	1.5	0.5	0
SCJB-15C	M2.6	1	18,000	0.5	0.25	200	3.5×10 ⁻⁷	10	2	0.3	0
SCJB-20C	M2.6	1	12,000	1	0.5	300	1.3×10 ⁻⁶	20	2	0.5	0
SCJB-25C	M3	1.7	9,000	2	1	700	3.4×10 ⁻⁶	35	2	0.5	0
SCJB-32C	M4	3.5	7,000	4	2	1,000	1.2×10 ⁻⁵	75	2	0.5	0
SCJB-40C	M5	8	5,000	10	5	1,800	3.3×10 ⁻⁵	145	2	0.5	0
SCJ-15	M3	0.7	21,000	0.5	0.25	200	2.9×10 ⁻⁷	9	1.5	0.3	0
SCJ-20	M3	0.7	16,000	1	0.5	450	1.0×10 ⁻⁶	20	1.5	0.5	0
SCJ-25	M4	1.7	12,000	2	1	800	3.1×10 ⁻⁶	35	1.5	0.5	0
SCJ-32	M4	4	9,000	4	2	1,200	1.1×10 ⁻⁵	75	1.5	0.5	0
SCJ-40	M5	4	7,000	10	5	1,900	3.1×10 ⁻⁵	145	1.5	0.5	0

* Mass and mass moment of inertia are measured with max. bore size

Dimensions and Standard Inner Diameter

Product Number	Dimension (mm) (±0.3)						Dimensions and Standard Inner Diameter(d ₁ , d ₂ , unit:mm)										
	D	L	L ₁	E	t	F	3	4	5	6	6.35	8	10	11	12	14	15
SCJA-15C	15	22.2	8	2.7	0.7	2.95	●	●	●	●							
SCJA-20C	20	23.4	7.9	4.2	0.8	2.75		●	●	●	●	●					
SCJA-25C	25	30.4	10.4	5.2	1.3	3.55			●	●	●	●	●				
SCJA-32C	32	39	13.5	8.2	1.6	4.4				●	●	●	●	●	●	●	
SCJA-40C	40	45.6	16	10	1.8	5.9						●	●	●	●	●	●
SCJB-15C	15	24.2	8	2.7	1.7	2.95	●	●	●	●	●						
SCJB-20C	20	26.4	7.9	4.2	2.3	2.75		●	●	●	●	●					
SCJB-25C	25	33.4	10.4	5.2	2.8	3.55			●	●	●	●	●				
SCJB-32C	32	43	13.5	8.2	3.6	4.4				●	●	●	●	●	●	●	
SCJB-40C	40	51	16	10	4.5	5.9						●	●	●	●	●	●
SCJ-15	15	22.2	8	2.7	0.7	3.85	●	●	●	●	●						
SCJ-20	20	23.4	7.9	4.2	0.8	3.75		●	●	●	●	●					
SCJ-25	25	30.4	10.4	5.2	1.3	4.95			●	●	●	●	●				
SCJ-32	32	39	13.5	8.2	1.6	6.55				●	●	●	●	●	●	●	
SCJ-40	40	45.6	16	10	1.8	7.8						●	●	●	●	●	●

- For the inner diameter, INCH type is available
- Nonstandard inner diameter is also available
- Keyway is available
- The recommendation for shaft tolerance is h7.