

TRUSCO **Stock 38,650 Items**

Diamond Taper File (for mold and precision finishing)



- Features**
- The precision of the tip portion necessary for finishing, modification and R removal of various molding die is superior.
 - We prepared the optimum grain size for molding die precision finishing.
 - The blade metal has elasticity and fits the work material.
- Use**
- Finishing, modification, R removal and grinding various blade of various molding die.
 - Rib groove processing of plastic molding die.
 - For small diameter hole, chamfer.
- Origin**
- Japan

Item No.	Materials
TK-7	Piano Wire (hard iron wire)
TK-6	SK-2
TK-5	SK-2
TK-4	SK120
TK-3	SK120
TK-2	SK120
TK-1	SK120

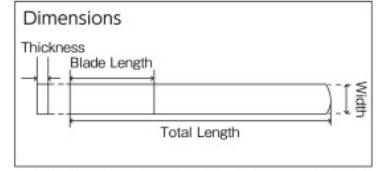

Warning
Please wash with a toothbrush etc. in case of clogging.

Order Unit: 1 Piece

Order Code	Item No.	Price (per piece)	MSRP (per piece)	Grain Size (#)	Shape	Total Length (mm)	Blade Length (mm)	SPQ (piece)	Weight (g)
430-6988	TK-7	¥1,944	¥2,100	270	Round (φ) 1.0	175	40	5	1.0
430-6970	TK-6	¥2,592	¥2,800	270	Small Taper (width) 4.0 x (thickness) 0.5	170	40	5	7.4
430-6961	TK-5	¥2,370	¥2,560	270	Super smooth hand (width) 2.5 x (thickness) 0.5	150	40	5	2.7
352-0901	TK-4	¥2,916	¥3,150	270	Hand (width) 3.2 x (thickness) 0.6	170	40	5	8.0
352-0919	TK-3	¥3,518	¥3,800	270	Hand (width) 6.2 x (thickness) 0.6	185	40	5	19.0
352-0927	TK-2	¥4,258	¥4,600	270	Hand (width) 8.2 x (thickness) 0.6	200	40	5	31.0
352-0935	TK-1	¥4,860	¥5,250	270	Hand (width) 10.0 x (thickness) 0.7	215	40	5	49.0

Contact us: 0120-509-849 <http://www.orange-book.com/>

TRUSCO NAKAYAMA CORPORATION

TRUSCO **Stock 38,650 Items**

Diamond Taper File (for mold, rough filing to finishing)

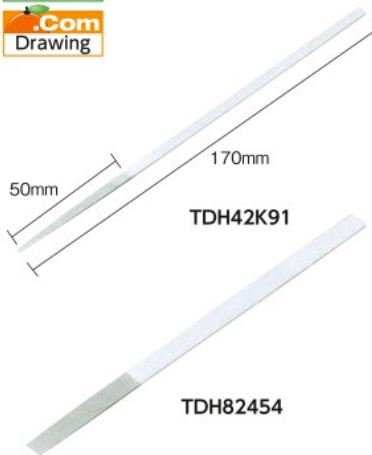

- Features**
- File base: Dimensional precision is high and there is moderate bend.
 - Diamond: Custom diamond is excellent in wear resistance and grinding force.
 - Coating: Since it is uniform, it has strong holding power and is difficult to remove.
 - Optimum for grinding and polishing of hardened material.
 - For rib groove processing of plastic molds.
 - Chamfering, grinding, finish polishing, etc.
- Materials**
- Chromium molybdenum steel (approximately HRC45)
 - Diamond abrasive grains
 - Nickel (electrodeposited bond)
 - Chrome (coating)
- Origin**
- Israel

Warning
Use with light contact and thoroughly clean with a brush when there is clogging.

Order Unit: 1 Piece

(Price revision date: Jan, 2016) TRUSCO NAKAYAMA CORPORATION

Order Code	Item No.	Price (per piece)	MSRP (per piece)	Grain Size (#)	Dimensions (mm) T x T1 x N x N1	Total Length (mm)	Blade Length (mm)	SPQ (piece)	Weight (g)
302-2307	TDH42126	¥4,730	¥5,110	120	0.70 x 2.30 x 3.30 x 4.0	170	50	1	9
302-2277	TDH42K91	¥4,730	¥5,110	170	0.65 x 2.25 x 2.25 x 4.0	170	50	1	9
302-2293	TDH4291	¥4,730	¥5,110	170	0.65 x 2.25 x 3.25 x 4.0	170	50	1	9
302-2315	TDH62491	¥5,267	¥5,690	170	0.65 x 2.60 x 6.25 x 6.0	170	50	1	18
302-2331	TDH82491	¥6,859	¥7,410	170	0.65 x 2.40 x 8.35 x 8.0	170	50	1	20
302-2285	TDH4254	¥4,730	¥5,110	325	0.55 x 2.20 x 3.15 x 4.0	170	50	1	9
302-2323	TDH82454	¥6,859	¥7,410	325	0.55 x 2.35 x 8.30 x 8.0	170	50	1	20

Contact us: 0120-509-849 <http://www.orange-book.com/>

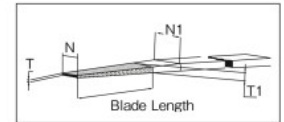

TRUSCO **Stock 38,650 Items**

Diamond Taper File (for mold, super precision finishing)

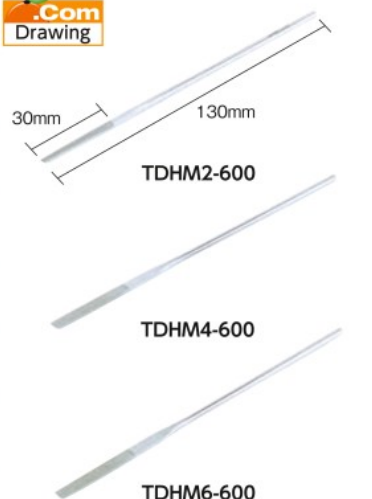

- Features**
- Suitable for thin shafts and precision processing.
 - File base: Dimensional precision is high and there is moderate bend.
 - Diamond: Custom diamond is excellent in wear resistance and grinding force.
 - Coating: Since it is uniform, it has strong holding power and is difficult to remove.
 - For grinding and polishing of hardened materials.
 - For rib groove processing of plastic molds.
 - For processing of narrow grooved portions.
 - For chamfering, grinding, and finish polishing.
- Materials**
- Chromium molybdenum steel (approximately HRC45)
 - Diamond abrasive grains
 - Nickel (electrodeposited bond)
 - Chrome (coating)
- Origin**
- Israel

Order Unit: 1 Piece

(Price revision date: Jan, 2016) TRUSCO NAKAYAMA CORPORATION

Order Code	Item No.	Price (per piece)	MSRP (per piece)	Grain Size (#)	Dimensions (mm) T x T1 x N x N1	Total Length (mm)	Blade Length (mm)	SPQ (piece)	Weight (g)
480-5585	TDHM2-600	¥4,054	¥4,380	600	0.35 x 2.70 x 2.05 x 2.0 x 3.0	130	30	1	6
480-5593	TDHM4-600	¥4,054	¥4,380	600	0.35 x 1.30 x 4.05 x 4.0 x 3.0	130	30	1	6
480-5607	TDHM6-600	¥4,054	¥4,380	600	0.35 x 1.35 x 5.55 x 5.5 x 3.0	130	30	1	7

Contact us: 0120-509-849 <http://www.orange-book.com/>

