

High-Speed Steel Drills (step type)

Stock 2,132 Items

Prices displayed include 8% tax.

TRUSCO
 Stock 38,650 Items

Stepped Drill (for hex socket head cap screw)

Regrinding OK RoHS

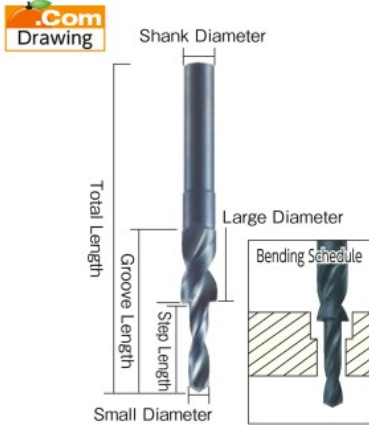

- Features
- For Hex Socket Head Cap Screw
 - For JIS B 1176 bolt hole and counter boring machining.
- Use
- Work material: Cast iron, carbon steel, alloy steel, tool steel, stainless steel, aluminum alloy.
- Materials
- High Speed Steel (HSS)
- Origin
- Japan

Order Unit: 1 Piece

TRUSCO NAKAYAMA CORPORATION

Order Code	Item No.	Price (per piece)	MSRP (per piece)	Small Diameter (mm)	Large Diameter (mm)	Step Length (mm)	Groove Length (mm)	Total Length (mm)	Shank Diameter (mm)	SPQ (piece)
409-8641	TSRMM3	¥ 2,754	¥ 3,400	3.4	6.5	13	25	65	6	1
409-8650	TSRMM4	¥ 2,981	¥ 3,680	4.5	8.0	18	35	75	6	1
409-8668	TSRMM5	¥ 3,159	¥ 3,900	5.5	9.5	22	40	85	8	1
409-8676	TSRMM6	¥ 3,904	¥ 4,820	6.6	11.0	25	45	90	8	1
409-8684	TSRMM8	¥ 4,941	¥ 6,100	9.0	14.0	28	55	100	12	1
409-8692	TSRMM10	¥ 5,702	¥ 7,040	11.0	17.5	30	60	110	12	1
409-8706	TSRMM12	¥ 8,019	¥ 9,900	14.0	20.0	32	65	115	12	1
409-8714	TSRMM14	¥ 9,720	¥ 12,000	16.0	23.0	35	75	125	12	1
409-8722	TSRMM16	¥ 11,340	¥ 14,000	18.0	26.0	40	85	135	12	1
409-8731	TSRMM18	¥ 12,798	¥ 15,800	20.0	29.0	45	95	145	12	1

TSRMM Series

Contact us:0120-509-849 <http://www.orange-book.com/>

TRUSCO
 Stock 38,650 Items

Stepped Drill (for countersunk head machine screw)

Regrinding OK RoHS

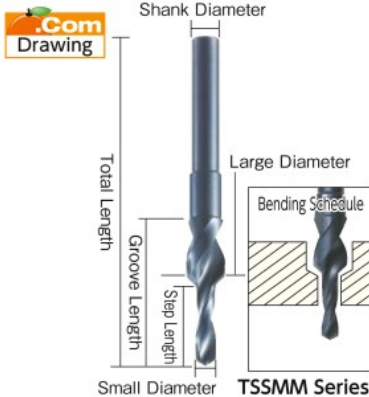

- Features
- For countersunk head screw.
 - For JIS B 1101 bolt hole and counter boring machining.
- Use
- Work material: Cast iron, carbon steel, alloy steel, tool steel, stainless steel, aluminum alloy.
- Materials
- High Speed Steel (HSS)
- Origin
- Japan

Order Unit: 1 Piece

TRUSCO NAKAYAMA CORPORATION

Order Code	Item No.	Price (per piece)	MSRP (per piece)	Small Diameter (mm)	Large Diameter (mm)	Step Length (mm)	Groove Length (mm)	Total Length (mm)	Shank Diameter (mm)	SPQ (piece)
409-8749	TSSMM3	¥ 2,754	¥ 3,400	3.4	6.4	13	25	65	6	1
409-8757	TSSMM4	¥ 2,997	¥ 3,700	4.5	8.4	18	30	70	6	1
409-8765	TSSMM5	¥ 3,775	¥ 4,660	5.5	10.4	22	35	80	8	1
409-8773	TSSMM6	¥ 4,358	¥ 5,380	6.6	12.5	25	40	85	10	1
409-8781	TSSMM8	¥ 5,832	¥ 7,200	9.0	16.5	28	45	90	12	1

TSSMM Series

Contact us:0120-509-849 <http://www.orange-book.com/>

TRUSCO
 Stock 38,650 Items

Stepped Drill (for cheese head screw)

Regrinding OK RoHS

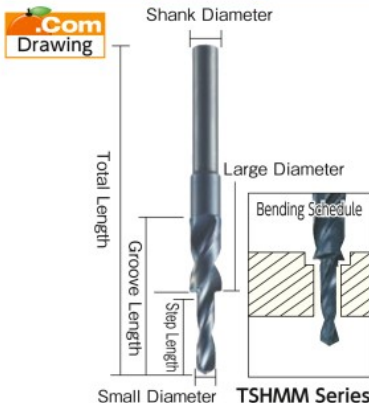

- Features
- For cheese head screw.
 - For JIS B 1101 bolt hole and counter boring machining.
- Use
- Work material: Cast iron, carbon steel, alloy steel, tool steel, stainless steel, aluminum alloy.
- Materials
- High Speed Steel (HSS)
- Origin
- Japan

Order Unit: 1 Piece

TRUSCO NAKAYAMA CORPORATION

Order Code	Item No.	Price (per piece)	MSRP (per piece)	Small Diameter (mm)	Large Diameter (mm)	Step Length (mm)	Groove Length (mm)	Total Length (mm)	Shank Diameter (mm)	SPQ (piece)
409-8790	TSHMM3	¥ 2,624	¥ 3,240	3.4	5.9	13	25	65	6	1
409-8803	TSHMM4	¥ 2,981	¥ 3,680	4.5	7.4	18	35	75	6	1
409-8811	TSHMM5	¥ 3,159	¥ 3,900	5.5	9.4	22	40	85	8	1
409-8820	TSHMM6	¥ 3,904	¥ 4,820	6.6	11.0	25	45	90	8	1
409-8838	TSHMM8	¥ 4,990	¥ 6,160	9.0	14.5	28	55	100	12	1

TSHMM Series

Contact us:0120-509-849 <http://www.orange-book.com/>

FUKUDASEIKO
 Stock 358 Items

Counterbore with Drill (for countersunk head machine screw)

Regrinding OK RoHS

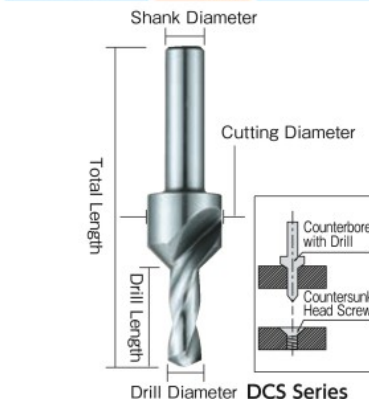

- Features
- A counterbore cutter for sinking the head of a flat head machine screw. By attaching a drill to the tip, drilling and countersinking can be done in one shot, shortening of processing time and tool cost can be reduced.
- Use
- Work material: Carbon steel, alloy steel, steel tools, cast iron, non-ferrous metal, aluminum alloy.
- Specs
- For Countersunk Head Machine Screw with Drill
- Materials
- High Speed Steel (SKH51)
- Origin
- Japan

Order Unit: 1 Piece

FUKUDASEIKO

Order Code	Item No.	Price (per piece)	MSRP (per piece)	Applicable Countersunk Head Machine Screw	Drill Diameter (mm)	Drill Length (mm)	Cutting Diameter (mm)	Total Length (mm)	Shank Diameter (mm)	Number of Blades	SPQ (piece)
323-7427	DCS3	¥ 2,895	¥ 3,300	M3	3.5	10	7.5	44	6	2	1
323-7435	DCS4	¥ 3,597	¥ 4,100	M4	4.5	15	9.5	55	6	2	1
323-7443	DCS5	¥ 4,476	¥ 5,100	M5	5.5	15	12.0	61	8	2	1
323-7451	DCS6	¥ 5,352	¥ 6,100	M6	6.5	20	14.0	71	10	2	1
323-7460	DCS8	¥ 7,371	¥ 8,400	M8	8.5	22	18.5	76	10	2	1

DCS Series

Contact us:072-984-6741 <http://www.fukudaseiko.co.jp/>

Coated Carbide Drills

Carbide Drills

High Speed Steel Coated Drills

High Speed Steel Drills

Thin Shaft Drills

Spot Cutters

Taper Shank Drills

Hex Shank Ironsmith Drills

Drill Sets

Drill Cases

Step Drills

Cutters for Magnetic Cutting Unit

Hole Saws

Core Drills

Concrete Drills

Drills

Bits, Cutters for Wood

For other cutting tools, see p. 1-805 to 1006