

マイクロチャック (ミーリングチャック)

BT[®]No-HPC[®]D-L
MICRON CHUCK (Milling Chuck)

>> センタースルー対応 Thru-the-tool Coolant Available

>> スキマスルー対応 Thru-the-groove Coolant Available

S 標準

FIG.1

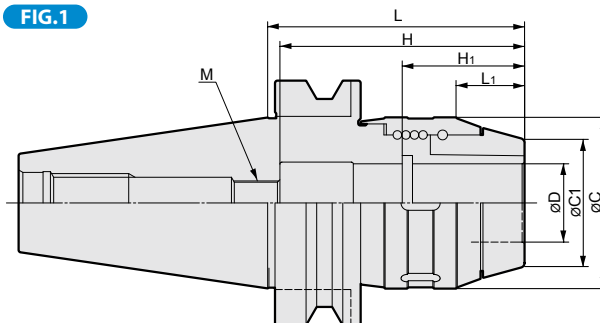

FIG.2

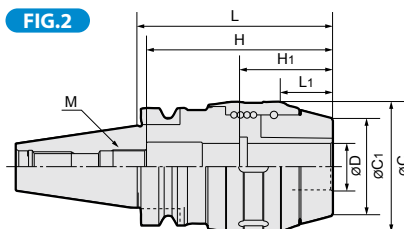
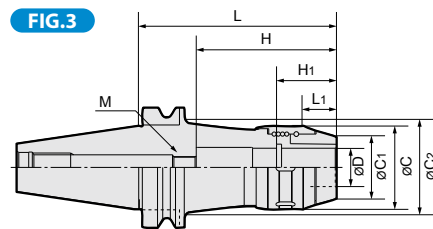

FIG.3

 シャンク公差h7以内の刃具をご使用下さい。
 Cutter shank diameter should be h7 or better.

MODEL	A級	AA級	BBT	Fig	øD	L	L1	øC	øC1	H	H1	調整量	M	N/W (kg)	
Max. 10,000 min ⁻¹															
BT30 (BBT30)	HPC16-	100	○	○	○	16	100	26	56	85	50	70~80	M10	1.4	
	HPC20-	100	○	○	○									34	38
	HPC25-	100	△	△	△	25	27.5	62	44	80	53	57~70	M16	1.6	
	HPC32-	105	△	△	△									70	52
Max. 10,000 min ⁻¹															
BT40 (BBT40)	HPC16-	090	○	○	○	16	90	26	56	85	50	70~80	M10	1.8	
	120	△	△	△	34									38	2.2
	HPC20-	090	○	○	○	20	90	27.5	62	44	100	77~90	M18	1.7	
	120	△	△	△	120									52	2.1
	HPC25-	105	○	○	○	25	105	27.5	62	44	100	77~90	M18	2	
	135	△	△	△	135									52	2.5
	HPC32-	105	○	○	○	32	105	27.5	70	52	117	94~107	M18	2.2	
	135	△	△	△	135									52	2.5
	HPC42-	135	△	△	△	42	135	30.5	82	62	100	57	77~90	M18	3.5