

Tタイプアダプター

- Material : Plated steel
- 材質 : SS(三価クロメートメッキ)

T-G1-R-R

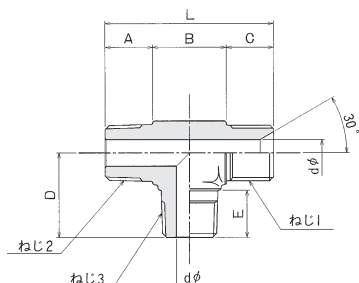

呼び径	ねじT ₁	ねじT ₂	ねじT ₃	Lmm	Amm	Bmm	Cmm	Dmm	Emm	dφmm
6	G $\frac{1}{4}$	R $\frac{1}{4}$	R $\frac{1}{4}$	46	13	20	13	23	13	5.5
9	G $\frac{3}{8}$	R $\frac{3}{8}$	R $\frac{3}{8}$	56	15	26	15	28	15	7.0
12	G $\frac{1}{2}$	R $\frac{1}{2}$	R $\frac{1}{2}$	64	18	28	18	32	18	10.0
19	G $\frac{3}{4}$	R $\frac{3}{4}$	R $\frac{3}{4}$	74	20	34	20	37	20	16.0
25	G 1	R 1	R 1	86	22	42	22	43	22	21.5

T-G1-G1-Rc

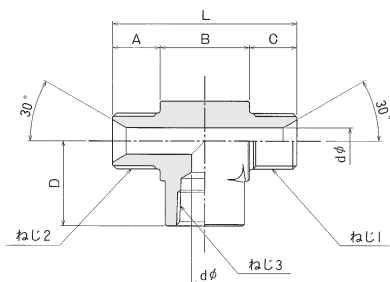

呼び径	ねじT ₁	ねじT ₂	ねじT ₃	Lmm	Amm	Bmm	Cmm	Dmm	dφmm
6	G $\frac{1}{4}$	G $\frac{1}{4}$	Rc $\frac{1}{4}$	50	13	24	13	23	5.5
9	G $\frac{3}{8}$	G $\frac{3}{8}$	Rc $\frac{3}{8}$	58	15	28	15	28	7.0
12	G $\frac{1}{2}$	G $\frac{1}{2}$	Rc $\frac{1}{2}$	70	18	34	18	32	10.0
19	G $\frac{3}{4}$	G $\frac{3}{4}$	Rc $\frac{3}{4}$	82	20	42	20	40	16.0

T-G1-Rc-G1

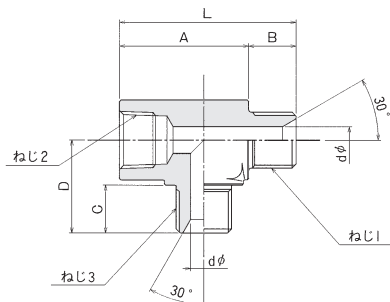

呼び径	ねじT ₁	ねじT ₂	ねじT ₃	Lmm	Amm	Bmm	Cmm	Dmm	dφmm
6	G $\frac{1}{4}$	Rc $\frac{1}{4}$	G $\frac{1}{4}$	48	35	13	13	25	5.5
9	G $\frac{3}{8}$	Rc $\frac{3}{8}$	G $\frac{3}{8}$	57	42	15	15	29	7.0
12	G $\frac{1}{2}$	Rc $\frac{1}{2}$	G $\frac{1}{2}$	67	49	18	18	35	10.0
19	G $\frac{3}{4}$	Rc $\frac{3}{4}$	G $\frac{3}{4}$	81	61	20	20	41	16.0

T-G1-Rc-Rc

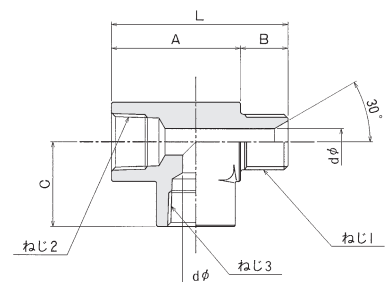
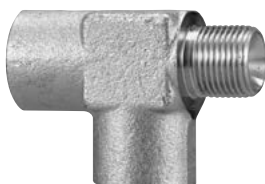

呼び径	ねじT ₁	ねじT ₂	ねじT ₃	Lmm	Amm	Bmm	Cmm	dφmm
6	G $\frac{1}{4}$	Rc $\frac{1}{4}$	Rc $\frac{1}{4}$	48	35	13	23	5.5
9	G $\frac{3}{8}$	Rc $\frac{3}{8}$	Rc $\frac{3}{8}$	57	42	15	28	7.0
12	G $\frac{1}{2}$	Rc $\frac{1}{2}$	Rc $\frac{1}{2}$	67	49	18	32	10.0
19	G $\frac{3}{4}$	Rc $\frac{3}{4}$	Rc $\frac{3}{4}$	81	61	20	40	16.0

(注意) 予告なしに、品質・性能・改善のため寸法を変更する事があります。