

Tool block for blades

DSGN 1

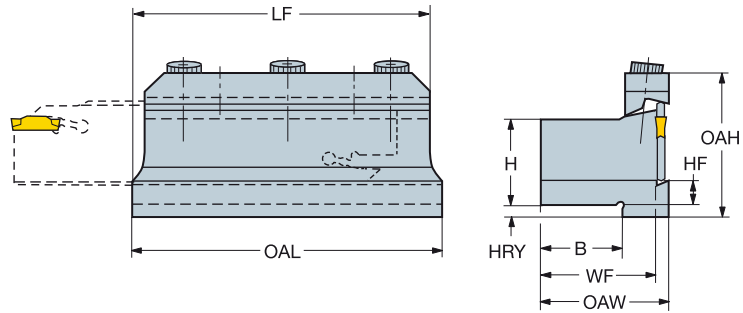

Metric version

CZC _{MS}	CZC _{WS}	CNCS	CXSC	Ordering code	Dimensions									Kg
					B	H	LF	WF	HF	OAW	OAH	RADH	RADW	
20 x 20	21	0	0	151.2-2020-21M	20	20	80	13	20	80	45	20	13	0.5
	25	0	0	151.2-2020-25	20	20	120	13	25	120	52	20	13	1.0
25 x 20	21	0	0	151.2-2520-21	20	25	80	13	25	80	45	25	13	0.6
	25	0	0	151.2-2520-25	20	25	120	13	25	120	52	25	13	1.2
32 x 32	25	0	0	151.2-3232-25	32	32	120	13	32	120	54	32	13	2.0
	45	0	0	151.2-3232-45	32	32	160	13	32	160	82	32	13	2.7
40 x 40	45	0	0	151.2-4040-45	40	40	160	13	40	160	82	40	13	4.2
50 x 50	93	0	0	151.2-5050-93	50	50	178	19	50	178	152	50	13	8.0

Inch version

CZC _{MS}	CZC _{WS}	CNCS	CXSC	Ordering code	Dimensions									Lbs
					B	H	LPR	LF	WF	HF	OAW	OAH	RADH	
3/4 x 3/4	21	0	0	151.2-12-21M	.750	.750	.730	3.150	.530	.750	3.150	1.790	.750	1.7
1 x 1	25	0	0	151.2-16-25M	1.000	1.000	.730	4.720	.530	1.000	4.720	1.790	1.000	3.3
1 1/4 x 1 1/4	25	0	0	151.2-20-25M	1.250	1.250	.730	4.720	.530	1.250	4.720	2.150	1.250	4.4
	45	0	0	151.2-20-45	1.250	1.250	.800	6.299	.530	1.250	6.299	3.250	1.250	9.2
1 1/2 x 1 1/2	25	0	0	151.2-24-25M	1.500	1.500	.730	4.720	.530	1.500	4.720	2.400	1.500	6.0
	45	0	0	151.2-24-45	1.500	1.500	.800	6.299	.530	1.500	6.299	3.250	1.500	9.2
2 x 2	93	0	0	151.2-32-93	2.000	2.000	1.146	7.008	.772	2.000	7.008	5.996	1.969	17.5



I1



I38

