

CoroTurn® 107 head for turning

Screw clamp design

CoroTurn® SL - High precision coolant supply

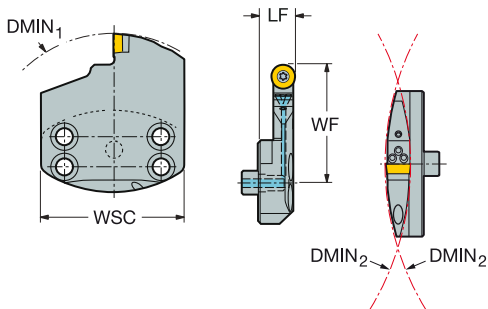

RCMT
RCGX-AL

		Dimensions, mm, inch													
CZC _{MS}	CDX	DMIN ₁	OHX	CNCS	Ordering code	LF	WF	WSC	HF	CP Bar/PSI	Nm	kg	MIID		
10	.394	70	20.0	120.0	17.0	1	SL70-SRDCL/L-20-10HP	17.0	41.0	70.0	0.0	30	3.0	0.25	RCMT 10 T3 M0
			.787	4.724	.669					.669	1.614	2.756	.000	435	.552
70			35.0	120.0	17.0	1	SL70-SRDCL/L-35-10HP	17.0	56.0	70.0	0.0	30	3.0	0.29	RCMT 10 T3 M0
			1.378	4.724	.669					.669	2.205	2.756	.000	435	.640
12	.472	70	35.0	120.0	18.0	1	SL70-SRDCL/L-35-12HP	18.0	56.0	70.0	0.0	30	3.0	0.40	RCMT 12 04 M0
			1.378	4.724	.709					.709	2.205	2.756	.000	435	.880
70			50.0	120.0	18.0	1	SL70-SRDCL/L-50-12HP	18.0	71.0	70.0	0.0	30	3.0	0.35	RCMT 12 04 M0
			1.969	4.724	.709					.709	2.795	2.756	.000	435	.770
70			75.0	120.0	18.0	1	SL70-SRDCL/L-75-12HP	18.0	96.0	70.0	0.0	30	3.0	0.44	RCMT 12 04 M0
			2.953	4.724	.709					.709	3.780	2.756	.000	435	.968

N = Neutral, R = Right hand, L = Left hand

