

T-Max® P boring bar for turning

Wedge clamp design

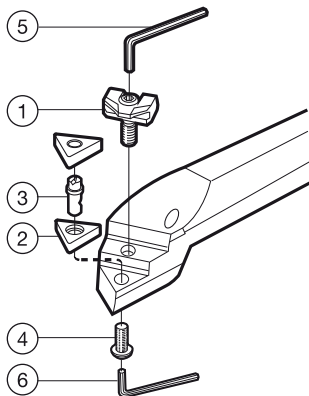

Metric version

	Spare parts				Included parts	
	1	2	3	4	5	6
Ordering code	Wedge set	Shim	Pin	Screw	Key	Key
A20S-MWLNRL 06	5431 125-011	5322 331-11	5313 022-02		170.3-860	170.3-864
A25T-MWLNRL 06	5431 125-011	5322 331-11	5313 022-02		170.3-860	170.3-864
A25T-MWLNRL 08	5431 125-021	5322 331-09	5313 022-03		174.1-864	
A32U-MWLNRL 06	5431 125-011	5322 331-06	5313 022-01	5512 030-03	170.3-860	170.3-864
A32U-MWLNRL 08	5431 125-021	5322 331-07	5313 022-03		174.1-864	
A40V-MWLNRL 08	5431 125-021	5322 331-07	5313 022-03	5512 030-04	174.1-864	174.1-863
A50W-MWLNRL 08	5431 125-021	5322 331-07	5313 022-03	5512 030-04	174.1-864	174.1-863

Inch version

	Spare parts				Included parts	
	1	2	3	4	5	6
Ordering code	Wedge set	Shim	Pin	Screw	Key	Key
S24V-MWLNRL 3	5431 125-011	5322 331-11	5313 022-02	5512 030-03	170.3-860	170.3-864
S32W-MWLNRL 3	5431 125-011	5322 331-06	5313 022-02	5512 030-03	170.3-860	170.3-864

Keys (mm/Torx Plus) sizes, see page P4
For optional shims, see page A131.