

# Replaceable Contact Point (Screw pitch M2.5 × 0.45mm)

for Dial Indicators and Linear Gauges

● Flat Contact Point

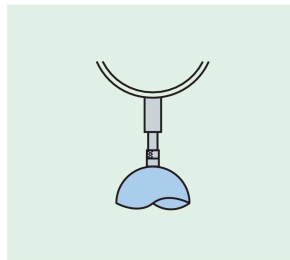
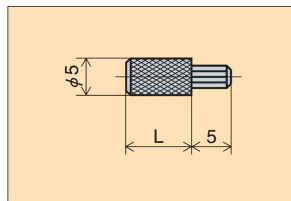

**XS-2**series

Part No.	L (mm)	Material
XS-2	8	SKS3
XS-205	5	SKS3
XS-210	10	SKS3
XS-215	15	SKS3
XS-220	20	SKS3
XS-225	25	SKS3
XS-230	30	SKS3

● Flat Contact Point

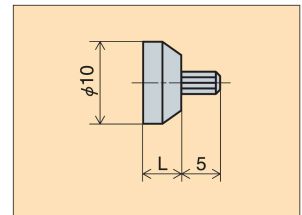

**XS-5**series

Part No.	L (mm)	Material
XS-5	5	SKS3
XS-510	10	SKS3

● Button type Contact Point

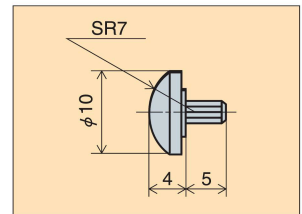

**XS-6**series

Part No.	Material
XS-6	SKS3

● Taper Contact Point

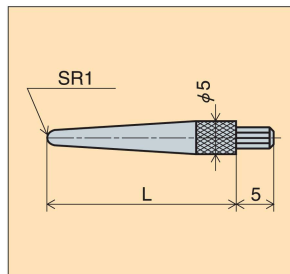

**XS-3**series

Part No.	L (mm)	Material
XS-3	25	SKS3
XS-310	10	SKS3
XS-315	15	SKS3
XS-320	20	SKS3
XS-330	30	SKS3

● Contact Point set XS



※XS is provided with setting table for XS-1 to XS-6 contact points, and a case. Each type sold separately.

Part No.	Material
XS	SKS3

● Plain Contact Point

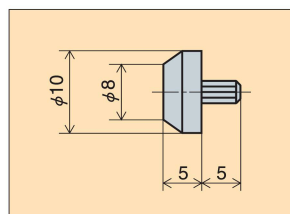

**XS-4**series

Part No.	Material
XS-4	SKS3

● Knife-edge Contact Point

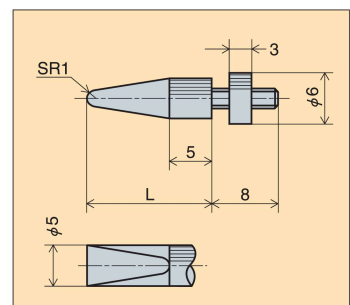

Part No.	L (mm)	Material
XS-710	10	SKS3
XS-715	15	SKS3
XS-720	20	SKS3
XS-725	25	SKS3
XS-730	30	SKS3