

TAR-Z Miniature Z - axis Rack - and - Pinion Stages

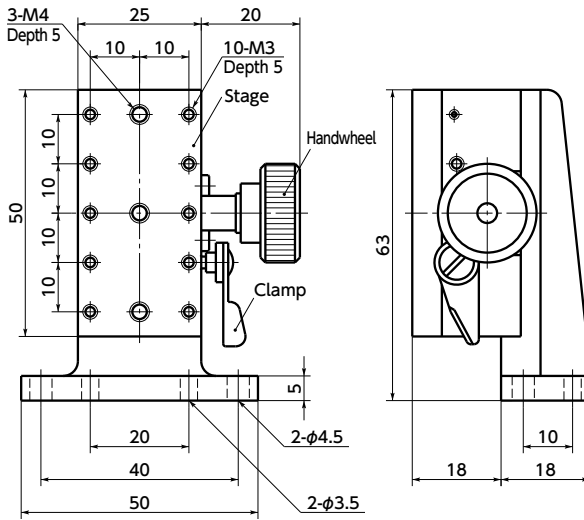

WEB Selection Tool WEB CAD Download



- Z-axis stage on the vertical stage surface.
- Rack-and-pinion method allows for quicker feeding.
- Dovetail groove method is adopted for the travel guide. A rattle correction function is provided.

● Material/Finish

RoHS Compliant

	TAR-Z
Stage	Brass Black chrome plating
Main body	Brass Coating (Silver)
Lower surface spacer	Aluminum Alloy Alumite Treatment (Black)

Unit : mm

Part Number	Stage Face	Travel Guide	Travel distance	Stroke (mm/Rotation)	Mass (g)
TAR-2550Z	25×50	Dovetail Groove Method	± 10	20	300

Unit : mm

Part Number	Straightness	Squareness	Display Resolution	Position Resolution	Withstand load (N)
TAR-2550Z	0.03	0.05	0.1	0.1	9.8

- Pan head machine screws for mounting (M3 x 10 and M4 x 10) are provided.

- Part number specification

TAR-2550Z

