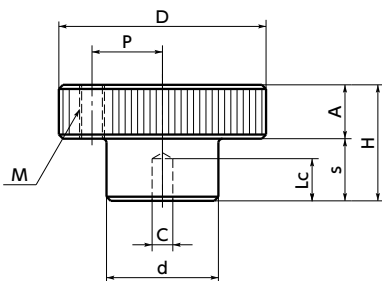
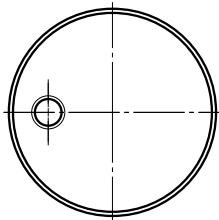

# HAK Aluminum Knurled Handwheel *Recommendation*

WEB Selection Tool    WEB CAD Download

**HAK**

With pilot hole and grip mounting hole

**HAK-N**

With pilot hole and without grip mounting hole

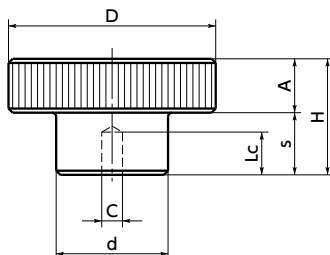
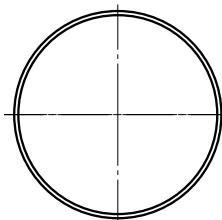
**HAK-FH**

With pilot hole and finger hole

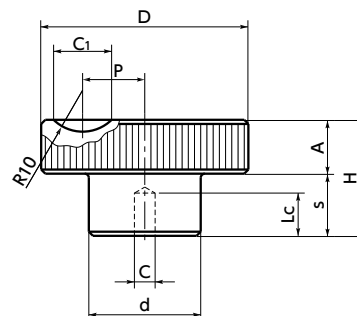
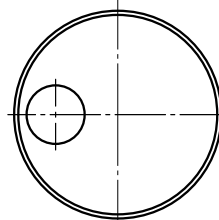
**HAK-R**

With reamer bore and grip mounting hole

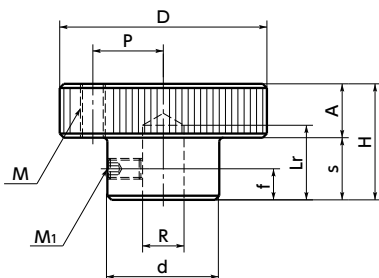
**HAK-R-N**

With reamer bore and without grip mounting hole

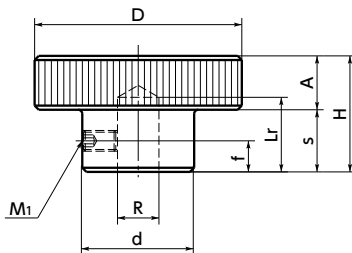
**HAK-R-FH**

With reamer bore and finger hole

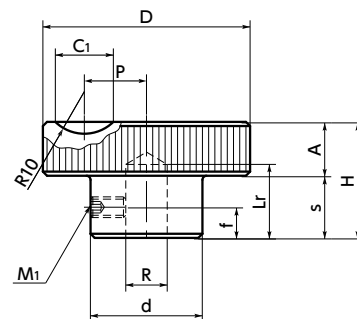
**HAK** With pilot hole and grip mounting hole    **HAK-N** With pilot hole and without grip mounting hole

Unit : mm

Part Number With grip mounting holes	M	p	Part Number Without grip mounting holes	D	H	A	s	d	C	Lc	Mass (g)
<b>HAK-40</b>	M6	14.5	<b>HAK-40-N</b>	40	25	12	13	22	5	15	50
<b>HAK-50</b>	M6	17	<b>HAK-50-N</b>	50	28	13	15	27	5	15	87
<b>HAK-63</b>	M6	23	<b>HAK-63-N</b>	63	32	14	18	35	5	15	161
<b>HAK-80</b>	M6	30	<b>HAK-80-N</b>	80	40	15	25	45	5	15	299

**HAK-R** With reamer bore and grip mounting hole    **HAK-R-N** With reamer bore and without grip mounting hole

Unit : mm

Part Number With grip mounting holes	M	p	Part Number Without grip mounting holes	D	H	A	s	d	C	Lc	Mass (g)
<b>HAK-40</b>	M6	14.5	<b>HAK-40-N</b>	40	25	12	13	22	5	15	50
<b>HAK-50</b>	M6	17	<b>HAK-50-N</b>	50	28	13	15	27	5	15	87
<b>HAK-63</b>	M6	23	<b>HAK-63-N</b>	63	32	14	18	35	5	15	161
<b>HAK-80</b>	M6	30	<b>HAK-80-N</b>	80	40	15	25	45	5	15	299

\*1 Hex socket set screw is provided.

Cleanroom Wash & Packaging → P.792	Vibration Resistant → P.795	Laser Marking → P.806	Modification of Shaft Hole Diameter → P.800
Available / Add'l charge	Not Available	Available / Add'l charge	Please feel free to contact us