



クーラントタイプ調整ネジ

ADJUST SCREW FOR COOLANT TYPE



バックアップスクリュー

BACK-UP SCREW

CODE	d	D	L	C	H
M18-SN5	M18P=1.5	5	60	35	25
-SN11		11	50	25	
M22-SN5	M22P=1.5	5	70	45	25
-SN11		11	60	35	
-SN18		18	50	25	

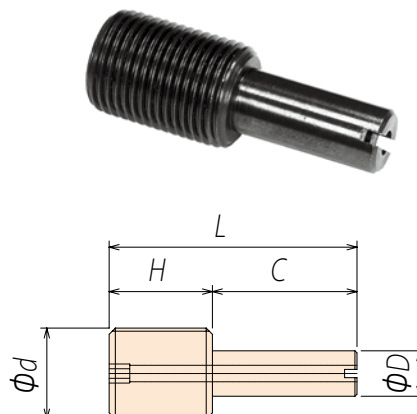

クーラントシールパッド付バックアップスクリュー

BACK-UP SCREW W/COOLANT SEAL

CODE	d	D	L	C	H	h
M18-CP9	M18P=1.5	9	50	25	25	4
-CP15		15	30	6	24	
M22-CP9	M22P=1.5	9	60	35	25	
-CP15		15	45	20	25	
-CP19		19	30	6	24	

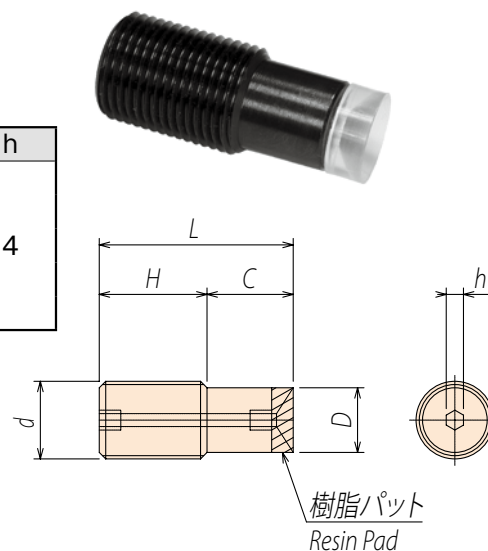

高圧用バックアップスクリュー

BACK-UP SCREW FOR HIGH PRESSURE

CODE	d	D	L	H	h	O-ring
HRMS11	M11P=1.0	8	25	10	2.5	N 4
HRMS15	M15P=1.5	12			3	P 6
HRMS18	M18P=1.5	15	30		4	P 9
HRMS22	M22P=1.5	19			5	P 12

