

# STRAIGHT PIN SETS

—STANDARD FIXING TYPE—

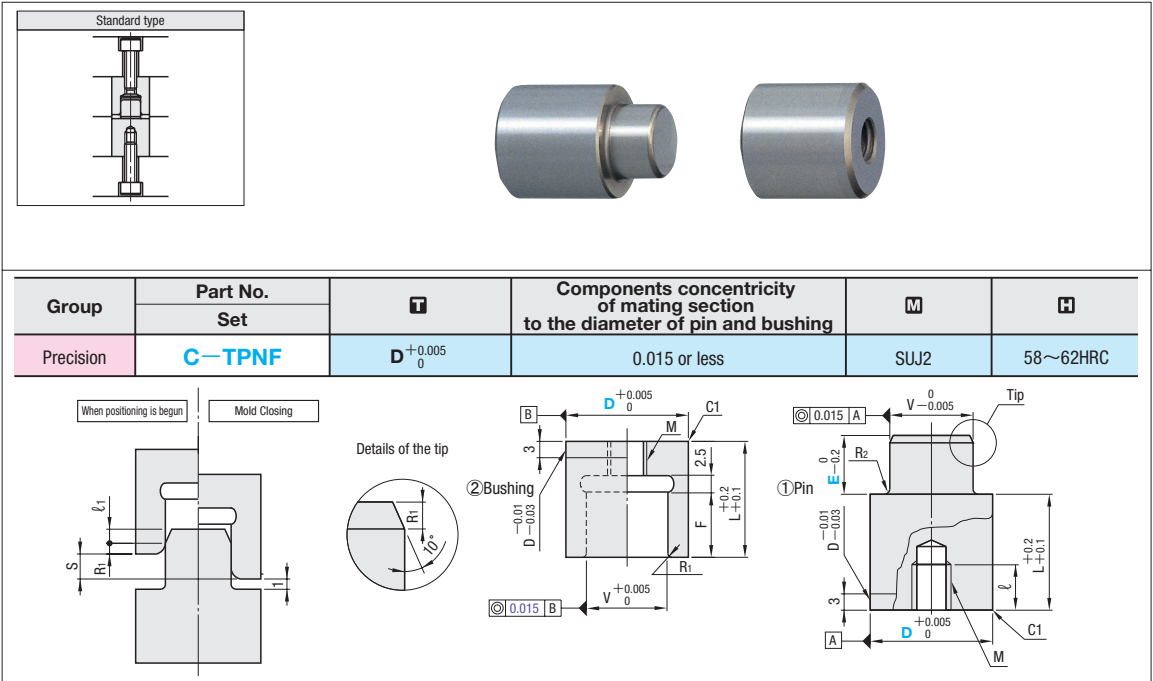

Installation bolt size	M	ℓ	V	ℓ1	R1	R2	F	L	S (Effective holding amount)	Part No.				
										Type	D	E		
M 4	4	10	5	1.0	0.5	0.8	5	14.5	4.5	C-TPNF (1)+(2)Set	10	7		
			7				11	24.5	10.5				13	13
			10				5	14.5	4.5					
M 5	5	12	13	2.0	1.0	1.5	6	14.5	5.5		20	11		
			9				19.5	8.5	25				13	
M 6	6	16	16	1.0	0.5	0.8	9	19.5			8.5	30		25
			11				24.5	10.5	25		13			
M 8	8	20	20	2.0	1.0	1.5	18	34				16.0	30	25
			23				39	21.0	30		25			



Order

Part No. — E  
C-TPNF 13 — 7



Days to Ship

Stock



Price

Order / Quote:  
WOS: <https://in.misumi-ec.com/>  
TEL: +91-124-468-8800 E-mail: [cs@misumi.co.in](mailto:cs@misumi.co.in)

## ■ Features

- Suitable for positioning in precision molds such as connector and electronic device.
- It is capable of preventing wear and damage in core pins, since it can be positioned before core is inlaid on cavity.
- For the PL installation type, installation and removal can be performed along the parting line for easy maintenance.

## ■ Usage

- Contacting the pin and bushing when mold is closed may cause damage. Please leave a clearance of about 1mm on PL.
- Use precision leader pins since clearance is fairly small.

