

JIS B2401-1 G番(円筒面固定用・平面固定用)

G

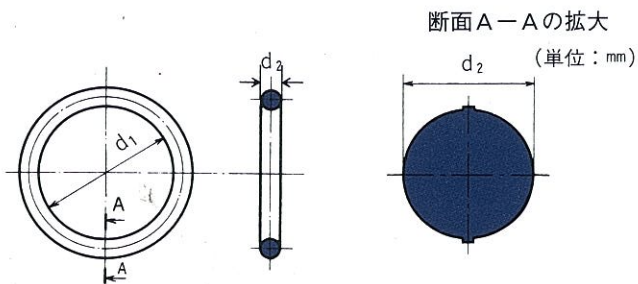

Oリングの形状・寸法

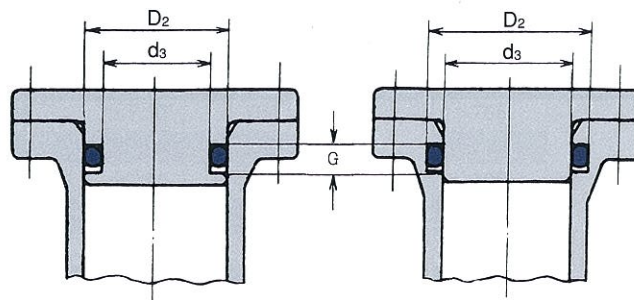

円筒面固定用

部品番号	JIS 呼び番号	Oリング寸法					円筒面固定用みぞ部の寸法			
		太さ d_2	内径			d_3	D_1			
			d_1	材料別許容差						
			材質群①	材質群②	材質群③					
20003	※G3	3.1±0.1	2.4	±0.14	±0.17	±0.21				
20004	※G4		3.4	±0.14	±0.17	±0.21				
20005	※G5		4.4	±0.15	±0.18	±0.23				
20006	※G6		5.4	±0.15	±0.18	±0.23				
20007	※G7		6.4	±0.16	±0.19	±0.24				
20008	※G8		7.4	±0.16	±0.19	±0.24				
20009	※G9		8.4	±0.17	±0.21	±0.26				
20010	※G10		9.4	±0.17	±0.21	±0.26				
20011	※G11		10.4	±0.18	±0.22	±0.27				
20012	※G12		11.4	±0.18	±0.22	±0.27				
20013	※G13		12.4	±0.19	±0.23	±0.29				
20014	※G14		13.4	±0.19	±0.23	±0.29				
20015	※G15		14.4	±0.20	±0.24	±0.3				
20016	※G16		15.4	±0.20	±0.24	±0.3				
20017	※G17		16.4	±0.21	±0.25	±0.32				
20018	※G18		17.4	±0.21	±0.25	±0.32				
20019	※G19		18.4	±0.22	±0.27	±0.33				
20020	※G20		19.4	±0.22	±0.27	±0.33				
20021	※G21		20.4	±0.23	±0.28	±0.35				
20022	※G22		21.4	±0.24	±0.28	±0.36				
20023	※G23		22.4	±0.24	±0.28	±0.36				
20024	※G24		23.4	±0.24	±0.29	±0.36				
20025	G25		3.1±0.1	24.4	±0.25	±0.30	±0.38	25		30
20030	G30			29.4	±0.29	±0.35	±0.44	30		35
20035	G35	34.4		±0.33	±0.40	±0.50	35		40	
20040	G40	39.4		±0.37	±0.45	±0.56	40		45	
20045	G45	44.4		±0.41	±0.50	±0.62	45		50	
20050	G50	49.4		±0.45	±0.54	±0.68	50		55	
20052	※G52	51.4		±0.47	±0.57	±0.71	52		57	
20055	G55	54.4		±0.49	±0.59	±0.74	55		60	
20058	※G58	57.4		±0.51	±0.62	±0.77	58	0	63	
20060	G60	59.4		±0.53	±0.64	±0.80	60	-0.10	65	
20062	※G62	61.4		±0.54	±0.65	±0.81	62		67	
20062	※G63	62.4		±0.55	±0.66	±0.83	63		68	
20062	※G64	63.4		±0.56	±0.68	±0.84	64		69	
20065	G65	64.4		±0.57	±0.69	±0.86	65		70	
20067	※G67	66.4		±0.59	±0.71	±0.89	67		72	
20070	G70	69.4		±0.61	±0.74	±0.92	70		75	
20072	※G72	71.4		±0.63	±0.76	±0.95	72		77	
20075	G75	74.4		±0.65	±0.78	±0.98	75		80	
20080	G80	79.4		±0.69	±0.83	±1.04	80		85	