

FBK80B

● Order No. Example

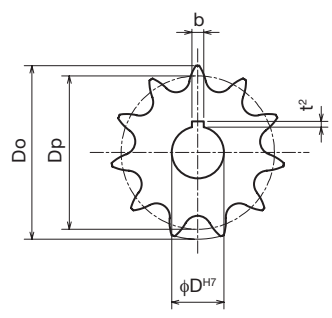
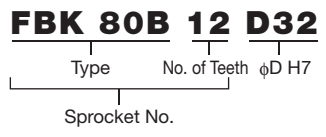

- Chain No.80
- Chain Pitch (P)25.4 mm
- Roller Link Inner Width (W)15.88mm
- Roller Outside Diameter (Dr)15.88mm
- Tooth Width (T)14.6 mm

Type	No. of Teeth	Outer Diameter Do	Pitch Diameter Dp	Boss Diameter BD	Boss Length BL	a	Weight kg	ϕD^H7	¥
FBK 80B	11	102	90.16	60	40	12	1.25	35 38	
	12	110	98.14	67	40	12	1.60	32	
	13	118	106.14	77	40	12	1.90	30 32 35 38	
	14	127	114.15	77	40	12	2.15	35 38 40	
	15	135	122.17	93	40	12	2.30	32 35 38 40	
	16	143	130.20	93	40	12	2.50	32 38 40	
	17	151	138.23	93	40	12	2.95	38 40	
	18	159	146.27	93	40	12	3.15	25 32 38 40	
	19	167	154.32	93	40	12	3.40	35 40	
	20	176	162.37	93	40	12	3.60	40	
	21	184	170.42	93	40	12	3.85	40 45 50	