

Model HE-H HANDY HOLDER BATTERY POWERED UNIT

Auxiliary transportation tool by battery type magnetic force



To be used for transportation of cut plate or extra material at room temperature, as well as for retrieving smaller products. Attractive force and battery time are significantly improved!

[Application]

It is used as a holding tool for moving, transporting cut plate or extra material and/or retrieving smaller products e.t.c. In addition, when cleaning outskirts of machine tools and in case an amount of cut material is entangled and therefore can not be wiped out quickly, it can be applied, and also to removed cut waste by magnetic attraction.

[Features]

- Only with a small amount of electricity supply of UM1 (in case JIS Standard) alkali cell batteries, strong attractive force is achieved.
- It is handy type, which can be operated by one hand. Cordless, for use in the field or shop.
- As it is hybrid (complex structure of permanent and electro magnet), a work piece does not drop when the battery finishes discharging, it is safe!
- Battery can be changed easily without any tool. In addition, rechargeable battery available in the ordinary market can be used, too.



HE-HL5A



HE-HS5A

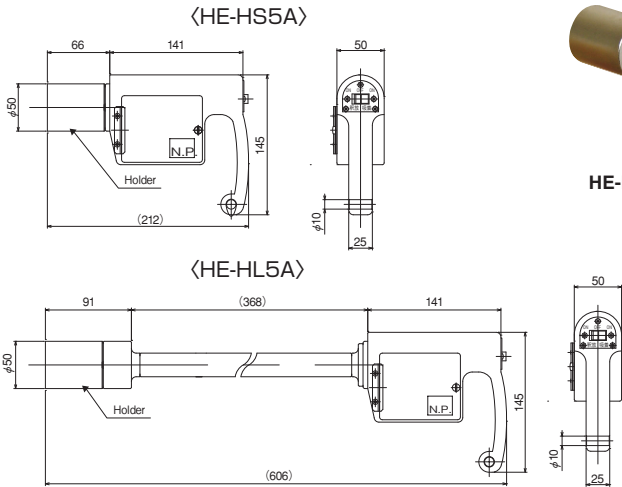

[mm (in)]

Model	Type	Holding Power	Power Source	Duty Cycle	Mass
HE-HS5A	Short type	600N (60kgf)	Single battery x 2	50% ED	1.8kg/3.96 lb
HE-HL5A	Long type	600N (60kgf)	Single battery x 2	50% ED	2.5kg/5.51 lb

※The attractive force is the value available on the face of SS400, (mild steel), plate thickness 15mm with finished surface by grinding.
 ※Mass includes dry cell battery.
 ※About one third of magnetic force remains when OFF position compared with strong (Absorption-ON)
 ※It is not designed for heat resistance or water proof.

Model SL TOUCHER



SL-1

[Application]

A simple transportation tool by use of a magnet.

[Features]

- You can easily carry workpieces which would otherwise be difficult to handle with hands due to complex shapes or high temperatures. Simply attract/remove with one-touch mechanism.
- Useful for tacking or positioning small pieces in welding operation.
- Usable for a wide range of applications.

[mm (in)]

Model	Holding Power	Dimensions			Max.Height	Mass
		Width	Length	Height		
SL-1	500N (50kgf)	50 (1.96)	92 (3.62)	32 (1.26)	122 (4.80)	1kg/2.2 lb

※The holding power is a value in a perpendicular direction on SS400, 110 steel sheet.

Model HMB HAND MAGNET



HMB-7

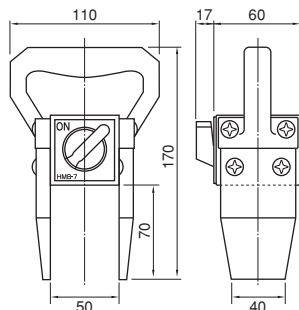

<Specifications>

- Capacity: Milling chips about 0.2 kg. M5 x 7 screws about 0.5 kg.

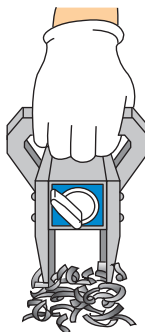

[Application]

This product is useful in wide applications such as in machine shops, casting factories, food and chemical factories, etc. for recovering iron chips, sorting materials of screws, etc., recovering chips in cast sand, etc.

[Features]

- Magnetic force is turned ON/OFF just by operating the lever lightly with a hand.
- Compact and strong holding power.

[mm (in)]

Model	Holding Power	Mass
HMB-7	250N (25kgf)	1.9kg/4.20 lb

※The holding power applies to SS400, thickness 10mm and ground surface.