

WN

ニップル

Male connector

黄銅製

Brass

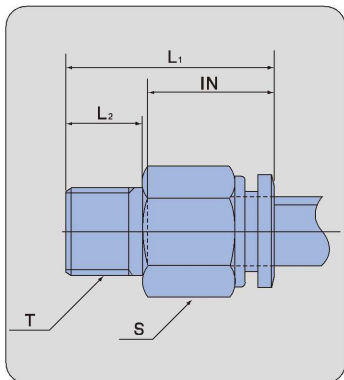

部品番号 PART NO.	適用チューブ 外径 TUBE O.D. TO BE USED (mm)	T (R)	S 六角 対辺 HEX (mm)	L ₁ (mm)	L ₂ (mm)	IN (mm)	重量 WEIGHT (g)	最小内径 ORIFICE (mm)	有効断面積 EFFECTIVE SECTIONAL AREA (mm ²)	
									ナイロンチューブ NYLON TUBE	ウレタンチューブ POLYURETHANE TUBE
WN-06-01	6	1/8	14	26	9	17	15	5.2	12.7	12.7
WN-06-02	6	1/4	14	26	12	17	20	5.2	12.7	12.7
WN-06-03	6	3/8	17	26	12	17	32	5.2	12.7	12.7
WN-08-01	8	1/8	17	29	9	18	25	6.3	26.9	18.0
WN-08-02	8	1/4	17	29	12	18	26	6.3	26.9	18.0
WN-08-03	8	3/8	17	29	12	18	34	6.3	26.9	18.0
WN-10-01	10	1/8	17	32	9	19	26	6.3	34.6	30.0
WN-10-02	10	1/4	17	32	12	19	26	8.0	42.9	30.0
WN-10-03	10	3/8	17	32	12	19	32	8.0	42.9	30.0
WN-10-04	10	1/2	22	36	16	19	58	8.0	42.9	30.0
WN-12-01	12	1/8	22	35	9	21	50	7.5	47.6	30.0
WN-12-02	12	1/4	22	34	12	21	45	9.0	55.2	30.0
WN-12-03	12	3/8	22	34	12	21	47	10.0	59.9	45.0
WN-12-04	12	1/2	22	35	16	21	59	10.0	59.9	45.0

WL

エルボ

Male elbow

樹脂製

Plastic body

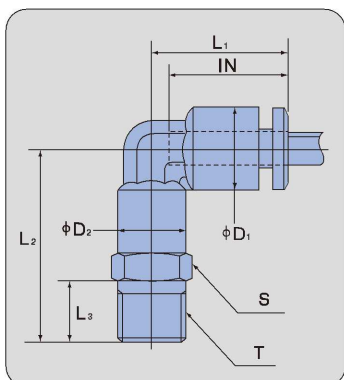

部品番号 PART NO.	適用チューブ 外径 TUBE O.D. TO BE USED (mm)	T (R)	φD ₁ (mm)	φD ₂ (mm)	S 六角 対辺 HEX (mm)	L ₁ (mm)	L ₂ (mm)	L ₃ (mm)	IN (mm)	重量 WEIGHT (g)	最小内径 ORIFICE (mm)	有効断面積 EFFECTIVE SECTIONAL AREA (mm ²)	
												ナイロンチューブ NYLON TUBE	ウレタンチューブ POLYURETHANE TUBE
WL-06-01	6	1/8	14	12	12	21	30.5	9	17	14	4.0	13.0	13.0
WL-06-02	6	1/4	14	12	14	21	33.5	12	17	20	4.0	13.0	13.0
WL-06-03	6	3/8	14	12	17	21	33.5	12	17	25	4.0	13.0	13.0
WL-08-01	8	1/8	17	14	14	23	32.5	9	18	18	6.0	25.0	11.6
WL-08-02	8	1/4	17	14	14	23	35.5	12	18	24	6.0	25.0	11.6
WL-08-03	8	3/8	17	14	17	23	35.5	12	18	29	6.0	25.0	11.6
WL-10-01	10	1/8	19	17	17	25	36.0	9	19	27	6.0	23.5	14.5
WL-10-02	10	1/4	19	17	17	25	37.0	12	19	29	7.5	27.0	20.5
WL-10-03	10	3/8	19	17	17	25	37.0	12	19	35	7.5	36.0	24.0
WL-10-04	10	1/2	19	17	22	25	41.0	16	19	41	7.5	36.0	24.0
WL-12-01	12	1/8	22	19	19	28	39.0	9	21	37	8.0	28.0	19.3
WL-12-02	12	1/4	22	19	19	28	40.0	12	21	39	9.0	45.0	36.0
WL-12-03	12	3/8	22	19	19	28	40.0	12	21	45	9.0	51.0	42.2
WL-12-04	12	1/2	22	19	22	28	44.0	16	21	61	9.0	55.0	42.2