

Polyurethane Wheel Type:  
Rigid Caster

# P-WK

Polyurethane Wheel Type:  
Wheel Only

# P-W

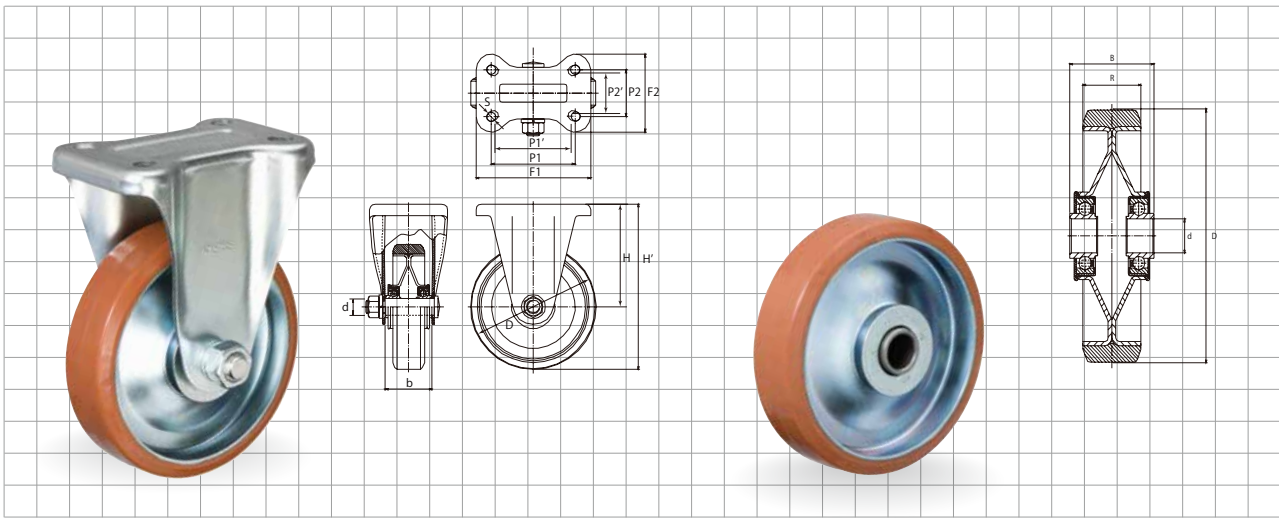

Product Name	Wheel diameter	Mounting Height	Bracket Height	Top plate	Hole pitch	Hole diameter	Fork width	Shaft	Maximum load		Quantity per case
	D	H'	H	F1/F2	P1/P2 (P1'/P2')	S	b	d	N	kg	Qty
<b>P-75WK</b>	<b>75</b>	100	63	95/72	63/40	9.5	36	10/M8	1176	120	40
<b>P-100WK</b>	<b>100</b>	144	94	115/80	80/45 (75/40)	10.5	43	12/M10	1764	180	20
<b>P-130WK</b>	<b>130</b>	177	112	137/93	100/56 (95/93)	11.5	52	20/M16	2450	250	10
<b>P-150WK</b>	<b>150</b>	198	123	137/93	100/56 (95/93)	11.5	56	20/M16	2940	300	10
<b>P-200WK</b>	<b>200</b>	250	150	151/102	112/63 (107/60)	11.5	56	20/M16	3920	400	5
<b>P-250WK</b>	<b>250</b>	305	180	200/140	140/80	14	90	25/M16	4900	500	2

Product Name	Wheel diameter	Bearing	Tire width	Boss width	Shaft	Maximum load		Quantity per case
	D		R	B	d	N	kg	Qty
<b>P-75W</b>	<b>75</b>	1030	32	35	10	1176	120	80
<b>P-100W</b>	<b>100</b>	1232	32	42	12	1764	180	50
<b>P-130W</b>	<b>130</b>	2042	35	52	20	2450	250	25
<b>P-150W</b>	<b>150</b>	2047	38	55	20	2940	300	20
<b>P-200W</b>	<b>200</b>	2047	42	55	20	3920	400	10
<b>P-250W</b>	<b>250</b>	2552	50	64	25	4900	500	5
<b>P-300W</b>	<b>300</b>	2552	50	71	25	5880	600	5

For Safe Use

Casters for Middle-Size Loads

Low Starting Resistance Casters

Caster for Tow Trolleys