



iglus®

# イグボールロッドエンドベアリング — EBR (L) M

EBR(L)M

イグボール ロッドエンド  
ベアリング EBR(L)M



標準タイプ

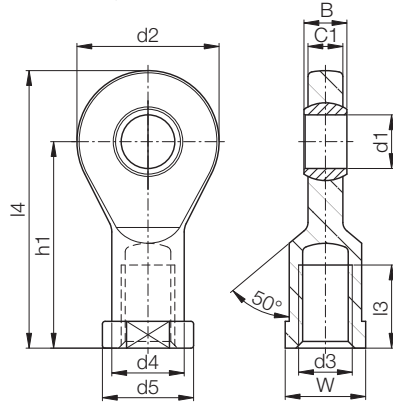

製品番号の構成

EBR(L)M-04

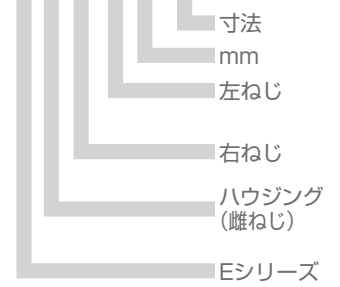

## 荷重データ

製品番号	最大静アキシ アル引張荷重		最大静ラジ アル荷重		最小 ねじ深さ [mm]	雌ねじの 最大許容 [Nm]	ボールの 最大許容 トルク [Nm]
	短期	長期	短期	長期			
	[N]	[N]	[N]	[N]			
EBR(L)M-04	800	400	100	50	7	0.4	2.0
EBR(L)M-05	1300	650	150	75	8	0.5	2.0
EBR(L)M-06	1500	750	200	100	8	1.5	2.5
EBR(L)M-08	2000	1000	450	225	11	5.0	7.0
EBR(L)M-10	2300	1150	500	250	13	15.0	14.0
EBR(L)M-10 F	2300	1150	500	250	13	6.0	14.0
EBR(L)M-12	3300	1650	550	275	14	20.0	25.0
EBR(L)M-12 F	3300	1650	550	275	14	15.0	25.0
EBR(L)M-15	4800	2400	800	400	18	25.0	30.0
EBR(L)M-16	5000	2500	850	425	18	20.0	32.0
EBR(L)M-16 F	5000	2500	850	425	18	15.0	32.0
EBR(L)M-17	5300	2650	1100	550	19	30.0	35.0
EBR(L)M-17 F	5300	2650	1100	550	19	27.5	35.0
EBR(L)M-20	7200	3600	1800	900	22	60.0	40.0
EBR(L)M-20 M20	7200	3600	1800	900	22	60.0	40.0
EBR(L)M-25	10000	5000	2600	1300	27	115.0	55.0
EBR(L)M-30	10500	5250	3000	1500	33	130.0	70.0

## 寸法 [mm]

製品番号	d1	d2	d3	d4	d5	C1	B	h1	l3	l4	W	最大ピボ ット角度
	E10											
EBR(L)M-04	4	15	M04	8.0	9.2	3.5	5	22.5	9.5	30.0	SW08	33°
EBR(L)M-05	5	19	M05	9.0	11	4.4	6	30	12	39.5	SW09	33°
EBR(L)M-06	6	21	M06	11.0	13	4.4	6	30	12	40.5	SW11	27°
EBR(L)M-08	8	24	M08	13.0	16	6.0	8	36	16	48.0	SW14	24°
EBR(L)M-10	10	29	M10	15.0	19	7.0	9	43	18	57.5	SW17	24°
EBR(L)M-10 F	10	29	M10 x 1.25	15.0	19	7.0	9	43	18	57.5	SW17	24°
EBR(L)M-12	12	34	M12	18.0	22	8.0	10	50	20	67.0	SW19	21°
EBR(L)M-12 F	12	34	M12 x 1.25	18.0	22	8.0	10	50	20	67.0	SW19	21°
EBR(L)M-15	15	40	M14	21.0	26	10.0	12	64.5	26.5	86.0	SW22	21°
EBR(L)M-16	16	43	M16	—	—	10.5	13	64.5	26.5	86.0	SW22	21°
EBR(L)M-16 F	16	43	M16 x 1.5	—	—	10.5	13	61	26	81.0	SW22	21°
EBR(L)M-17	17	46	M16	24.0	30	11.0	14	67	27	90.0	SW27	18°
EBR(L)M-17 F	17	46	M16 x 1.5	24.0	30	11.0	14	67	27	90.0	SW27	18°
EBR(L)M-20	20	53	M20 x 1.5	27.0	34	13.0	16	77	31	103.5	SW30	16°
EBR(L)M-20 M20	20	53	M20 x 2.5	27.0	34	13.0	16	77	31	103.5	SW30	16°
EBR(L)M-25	25	64	M24 x 2.0	34.0	41	17.0	20	94	38	126.5	SW36	16°
EBR(L)M-30	30	73	M30 x 2.0	41.0	48	19.0	22	110	47	146.5	SW41	13°

電話：03-5819-2030  
FAX：03-5819-2055

イグス株式会社

インターネット：www.igus.co.jp  
E-mail：info@igus.co.jp