

セルフグリップ(Tカット)

突切加工用ブレード

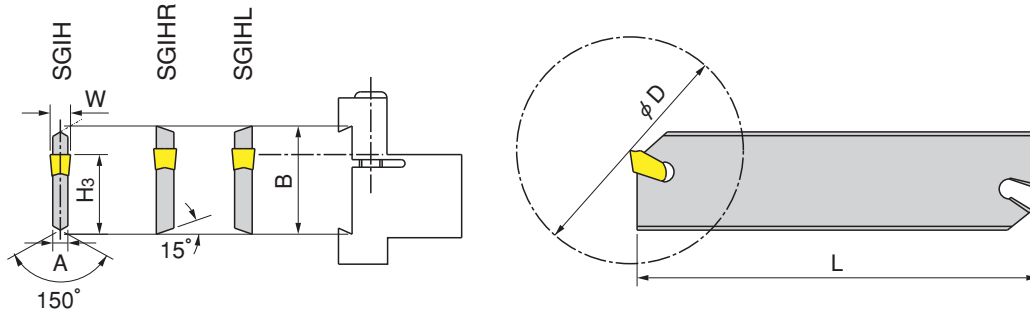
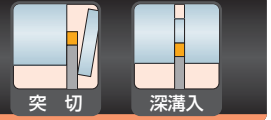

SGIH

SGIH,R/L

型番	在庫		寸法(mm)					取外しレンチ	Wチップ幅	適合チップ	適合ブロック	
	R	L	B	φDmax	A	L	H ₃					
SGIH 19-2	●		19.0	40	1.6	86	15.7	ESG-1	2.2/2.4	GTN/R/L 2/2.4	SGTBN-16-2 SGTBR/L19-2	
SGIH 26-2	●		26.0	50	1.6	110	21.4		3.1	GTN/R/L 3	SGTBN16-5 SGTBU□-5G SGTBR/L25-6 UBHCR/L20-26	
SGIH 26-3	●		26.0	75	2.4	110	21.4		4.1	GTN/R/L 4		
SGIH 26-4	●		26.0	80	3.2	110	21.4		4.8/5.1	GTN/R/L 4.8/5		
SGIH 26-5	●		26.0	80	4.0	110	21.4		6.4	GTN/R/L 6		
SGIH 26-6	○		26.0	80	5.2	110	21.4		2.2/2.4	GTN/R/L 2/2.4		SGTBU□-6G SGTBF□-A SGTBK32-9 UBHCR/L□-32
SGIH 32-2	●		32.0	40	1.6	150	25.0		3.1	GTN/R/L 3		
SGIH 32-3	●		32.0	100	2.4	150	25.0		4.1	GTN/R/L 4		
SGIH 32-4	●		32.0	100	3.2	150	25.0		4.8/5.1	GTN/R/L 4.8/5		
SGIH 32-5	●		32.0	120	4.0	150	25.0		6.4	GTN/R/L 6		
SGIH 32-6	●		32.0	120	5.2	150	25.0		8.0	GTN/R/L 8		
SGIHR/L 32-8	●	○	32.0	120	6.8	150	25.0		ESG-9	9.6	GTN/R/L 9	SGTBK40/50-9 SGTBN50-9 SGTBU40/50-9
SGIHR/L 32-9	●	○	32.0	120	8.0	150	25.0	8.0		GTN/R/L 8		
SGIH 52-8		○	52.6	190	6.8	190	45.0	9.6		GTN/R/L 9		
SGIH 52-9		○	52.6	190	8.0	190	45.0					
SGIH 53-9	●		52.6	250	8.0	260	45.0					

適合チップはC44頁をご参照下さい。
ツールブロックはD58～D60頁をご参照下さい。

Tカットをご使用の場合は、より高精度、レパートリーの多いFカット、ドゥーグリップを推奨します。