

セルフグリップ(Fカット)

突切加工用ブレード

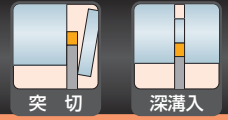

突切工具

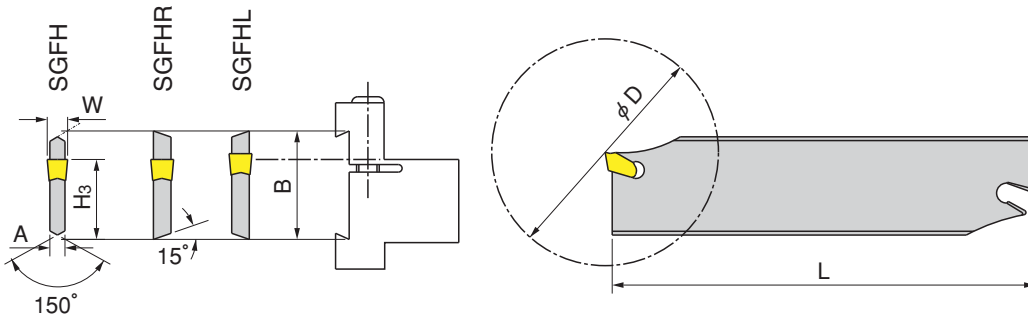

SGFH

SGFH,R/L

型番	在庫		寸法(mm)					取外し レンチ	Wチップ幅	適合チップ	適合ブロック
	R	L	B	φDmax	A	L	H ₃				
SGFH 19-1.2	●		19.0	18	0.93	86	15.7	ESG-0.5	1.2	GFN/R/L 1.2	SGTBN16-2 SGTBR/L19-2
SGFH 19-1	●		19.0	32	1.20	86	15.7		1.6	GFN/R/L 1.6	
SGFH 19-2	●		19.0	38	1.60	86	15.7		2.2/2.4	GFN/R/L 2/2.4	
SGFH 26-1.2	●		26.0	20	0.93	110	21.4	ESG-0.5	1.2	GFN/R/L 1.2	SGTBN16-5 SGTBU□-5G SGTBR/L25-6 UBHCR/L20-26
SGFH 26-1	●		26.0	35	1.20	110	21.4		1.6	GFN/R/L 1.6	
SGFH 26-2	●		26.0	50	1.60	110	21.4	ESG-1	2.2/2.4	GFN/R/L 2/2.4	
SGFH 26-3	●		26.0	75	2.40	110	21.4		3.0	GFN/R/L 3	
SGFH 26-4	●		26.0	80	3.20	110	21.4		4.1	GFN/R/L 4	
SGFH 26-5	○		26.0	80	4.00	110	21.4		4.8/5.1	GFN/R/L 4.8/5	
SGFH 32-1	●		32.0	38	1.20	150	24.8	ESG-0.5	1.6	GFN/R/L 1.6	SGTBF□-A SGTBU□-6G SGTBK32-9 UBHCR/L□-32
SGFH 32-2	●		32.0	50	1.60	150	24.8	ESG-1	2.2/2.4	GFN/R/L 2/2.4	
SGFH 32-3	●		32.0	100	2.40	150	24.8		3.0	GFN/R/L 3	
SGFH 32-4	●		32.0	100	3.20	150	24.8		4.1	GFN/R/L 4	
SGFH 32-5	●		32.0	120	4.00	150	24.8		4.8/5.1	GFN/R/L 4.8/5	
SGFH 32-6	●		32.0	120	5.20	150	24.8	6.4	GFN/R/L 6		
SGFHR/L 32-8		○	32.0	120	6.80	150	24.8	ESG-9	8.0	GFN/R/L 8	
SGFHR/L 32-9	○	○	32.0	120	8.00	150	24.8		9.5	GFN/R/L 9	
SGFH 45-3		○	45.0	160	2.40	225	38.0	ESG-1	3.0	GFN/R/L 3	SGTBU□-8M
SGFH 45-4	●		45.0	160	3.20	225	38.0		4.1	GFN/R/L 4	
SGFH 45-5	●		45.0	160	4.00	225	38.0		5.1	GFN/R/L 4.8/5	
SGFH 45-6	○		45.0	160	5.20	225	38.0		6.4	GFN/R/L 6	
SGFH 52-8		○	52.6	190	6.80	190	45.0	ESG-9	8.0	GFN/R/L 8	SGTBK40/50-9 SGTBN50-9 SGTBU40/50-9
SGFH 53-8		○	52.6	220	6.80	260	45.0		9.5	GFN/R/L 9	
SGFH 52-9		○	52.6	200	8.00	190	45.0				
SGFH 53-9		○	52.6	250	8.00	260	45.0		12.7	GFN/R/L 12W	
SGFHR/L 53-12	○	○	52.6	250	11.00	260	45.0				
SGFH 100-12*		○	100	450	11.00	450	92.5				受注製作
SGFH 150-12*		○	150	600	11.00	600	142.0				

*SGFH 100、150のブレードは4コーナー使用可能です。

適合チップはC38頁をご参照下さい。
ツールブロックはD58～D60頁をご参照下さい。