

ヘリグリッ
外径加工用一体型ホルダー

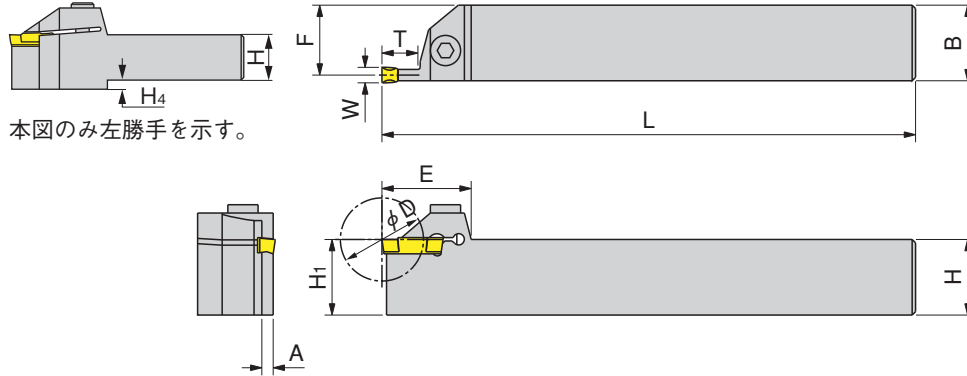
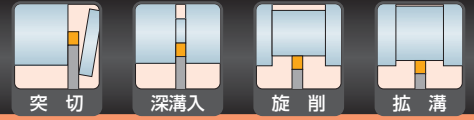

本図は右勝手を示す。

HELIR

突切工具

HELIR/L

型番	在庫		寸法 (mm)									スクリュー	レンチ	Wチップ幅	適合チップ							
	R	L	H=H ₁	B	φDmax	A	L	F	E	Tmax	H ₄				GRIP	HG□	DG□					
HELIR/L 1212-3T12	●	○	12	12	24	2.4	135	10.0	30.0	12	3	SR M5×16 DIN912	HW 4.0	3	3002Y 3003Y 3015Y	3002J 3003C	—					
HELIR/L 1616-3T12	●	●	16	16	24	2.4	135	14.8	30.0	12	—											
HELIR/L 1616-3T20	●	●	16	16	40	2.4	140	14.8	36.4	20	—	SR M6×20 DIN912	HW 5.0									
HELIR/L 2020-3T12	●	●	20	20	24	2.4	135	18.8	29.0	12	—	SR M5×16 DIN912	HW 4.0									
HELIR/L 2020-3T20	●	●	20	20	40	2.4	140	18.8	36.4	20	—	SR M6×20 DIN912	HW 5.0									
HELIR/L 2525-3T12	●	●	25	25	24	2.4	135	23.8	29.0	12	—	SR M5×16 DIN912	HW 4.0									
HELIR/L 2525-3T20	●	●	25	25	40	2.4	140	23.8	36.4	20	—	SR M6×20 DIN912	HW 5.0									
HELIR/L 3232-3T20	●	○	32	32	40	2.4	150	30.8	36.4	20	—	DIN912	HW 5.0									
HELIR/L 1616-4T12	●	○	16	16	24	3.2	135	14.4	29.0	12	4	SR M5×16 DIN912	HW 4.0	4	4002Y 4004Y 4020Y	—	40○○					
HELIR/L 1616-4T20	●	●	16	16	40	3.2	140	14.4	38.0	20	4	SR M6×20 DIN912	HW 5.0									
HELIR/L 2020-4T12	●	●	20	20	24	3.2	135	18.4	29.0	12	—	SR M5×16 DIN912	HW 4.0									
HELIR/L 2020-4T25	●	●	20	20	50	3.2	140	18.4	42.0	25	—	SR M6×20 DIN912	HW 5.0									
HELIR/L 2525-4T12	●	●	25	25	24	3.2	135	23.4	29.0	12	—	SR M5×16 DIN912	HW 4.0									
HELIR/L 2525-4T25	●	●	25	25	50	3.2	140	23.4	42.0	25	—	SR M6×20 DIN912	HW 5.0									
HELIR/L 3232-4T25	●	●	32	32	50	3.2	150	30.4	42.0	25	—											
HELIR/L 2020-5T12	●	●	20	20	24	4.2	135	17.9	29.0	12	—	SR M6×16 DIN912	HW 5.0					5	5005Y 5008Y 5025Y	—	50○○	
HELIR/L 2020-5T25	●	●	20	20	50	4.2	140	17.9	42.0	25	—	SR M6×20 DIN912										
HELIR/L 2525-5T12	●	●	25	25	24	4.2	135	22.9	29.0	12	—	SR M6×16 DIN912										
HELIR/L 2525-5T25	●	●	25	25	50	4.2	140	22.9	42.0	25	—	SR M6×20 DIN912										
HELIR/L 3232-5T25	●	●	32	32	50	4.2	150	29.9	42.0	25	—											
HELIR/L 2525-6T12	●	●	25	25	24	5.2	135	22.4	29.0	12	—	SR M6×16 DIN912		HW 5.0	6	6005Y 6008Y 6030Y	—					60○○ 63○○
HELIR/L 2525-6T30	●	●	25	25	60	5.2	140	22.4	51.4	30	—	SR M6×20 DIN912										
HELIR/L 3232-6T30	●	●	32	32	60	5.2	150	29.4	51.4	30	—	DIN912										

3mm幅のHELIR/Lホルダーにはヘリグリッ (HGN) チップが装着出来ます。
4mm幅以上のHELIR/Lホルダーにはドゥーグリッチップ (DGN) が装着出来ます。
それぞれ溝入れ加工専用です。

適合チップはC9～C11頁をご参照下さい。