

15MPa B型銅管くい込継手 (15kgf/cm²)

GL-2型

MALE ELBOW

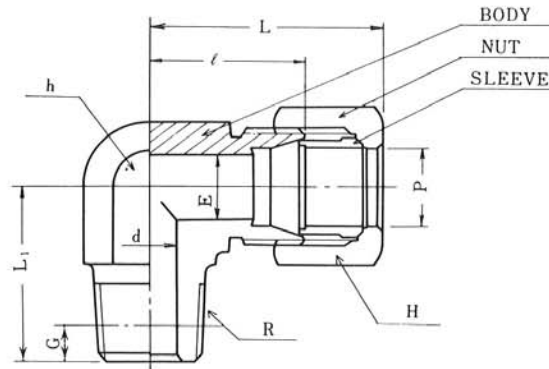

(注) L寸法はナットを締付け前の概略寸法を示す。

L denotes the rough dimensions before tightening the nuts. 単位：mm

継手の呼称 Designation of joints	各部の記号 Symbols of respective parts	適用する 管の外径 Tube (O.D.) P	Minimum Opening E	d	基準径の位置 Position of refer- ence diameter G	二面巾 Width Across Flats h	六角対辺 Opposite sides of hexagon H	ℓ	(約)	(約)	R (PT)
									Approx	Approx	
GL-2	4-R ¹ / ₈ -B	4	2.5	4	3.97	12	12	15	23	17	1/8
GL-2	6-R ¹ / ₈ -B	6	4	4	3.97	14	14	20	29.5	18	1/8
GL-2	6-R ¹ / ₄ -B	6	4	6	6.01	14	14	20	29.5	22	1/4
GL-2	6-R ³ / ₈ -B	6	4	8.5	6.35	19	14	24	33.5	27	3/8
GL-2	6-R ¹ / ₂ -B	6	4	12	8.16	23	14	27	36.5	34	1/2
GL-2	8-R ¹ / ₈ -B	8	6	4	3.97	17	17	22	33	20	1/8
GL-2	8-R ¹ / ₄ -B	8	6	6	6.01	17	17	22	33	25	1/4
GL-2	8-R ³ / ₈ -B	8	6	8.5	6.35	19	17	24	35	27	3/8
GL-2	8-R ¹ / ₂ -B	8	6	12	8.16	23	17	27	38	34	1/2
GL-2	10-R ¹ / ₈ -B	10	8	4	3.97	17	19	23	33.5	20	1/8
GL-2	10-R ¹ / ₄ -B	10	8	6	6.01	17	19	23	35.5	25	1/4
GL-2	10-R ³ / ₈ -B	10	8	8.5	6.35	19	19	24	35.5	27	3/8
GL-2	10-R ¹ / ₂ -B	10	8	12	8.16	23	19	27	38.5	34	1/2
GL-2	12-R ¹ / ₄ -B	12	10	6	6.01	19	21	24	36.5	27	1/4
GL-2	12-R ³ / ₈ -B	12	10	8.5	6.35	19	21	24	36.5	27	3/8
GL-2	12-R ¹ / ₂ -B	12	10	12	8.16	23	21	27	39.5	34	1/2
GL-2	14-R ³ / ₈ -B	14	11	8.5	6.35	23	26	29	41.5	30	3/8
GL-2	14-R ¹ / ₂ -B	14	11	12	8.16	23	26	29	41.5	34	1/2
GL-2	15-R ³ / ₈ -B	15	12	8.5	6.35	23	26	29	41.5	30	3/8
GL-2	15-R ¹ / ₂ -B	15	12	12	8.16	23	26	29	41.5	34	1/2
GL-2	16-R ¹ / ₂ -B	16	13	12	8.16	23	29	29	41.5	34	1/2
GL-2	18-R ¹ / ₂ -B	18	15	12	8.16	29	32	33	44	38	1/2
GL-2	20-R ¹ / ₂ -B	20	17	12	8.16	29	35	33	44	38	1/2
GL-2	20-R ³ / ₄ -B	20	17	17	9.53	29	35	33	45.5	40	3/4
GL-2	22-R ³ / ₄ -B	22	18	17	9.53	29	36	33	47	40	3/4
GL-2	25-R ³ / ₄ -B	25	20	17	9.53	35	41	36	49.5	42	3/4
GL-2	25-R 1-B	25	20	22	10.39	35	41	36	49.5	46	1
GL-2	28-R 1-B	28	22	22	10.39	41	41	44	57	54	1
GL-2	30-R 1-B	30	25	22	10.39	41	46	44	59	54	1
GL-2	32-R ¹ / ₄ -B	32	26	31	12.7	41	50	43	61	56	1 1/4