

Freebear Unit

RoHS CAD 3D Product with scrap removing function

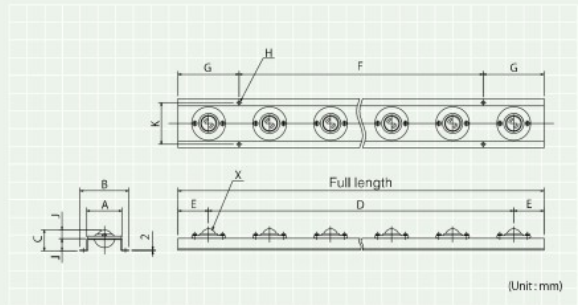

Model	A	B	C	D	E	F	G	H	I	J	Full length	K	X (Freebear)	Weight
FU-9-75	58	80	34.6	75 Pitch × 11 = 825	37.5	200 Pitch × 4 = 800	50	10- Ø 5.5	20	14.6	900	68.5	C-8L-SL4 (Qty.: 12)	3.0kg
FU-P9-75						200 Pitch × 8 = 1,600					1,800		P-8L-SL4 (Qty.: 12)	2.4kg
FU-18-75				75 Pitch × 23 = 1,725		1,800	C-8L-SL4 (Qty.: 24)	6.0kg						
FU-P18-75				200 Pitch × 8 = 1,600		1,800	P-8L-SL4 (Qty.: 24)	4.7kg						

You can choose the stainless steel freebears to mount according to the intended use.

Freebear Unit

RoHS CAD 3D

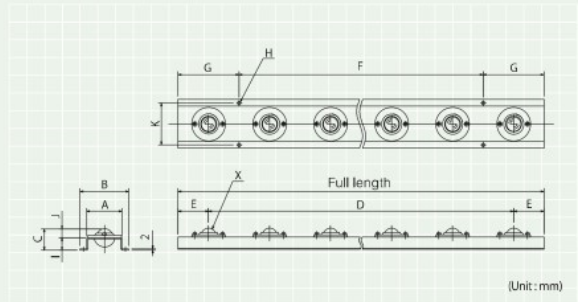
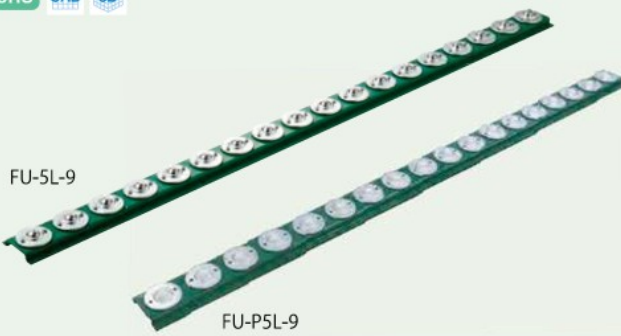

Model	A	B	C	D	E	F	G	H	I	J	Full length	K	X (Freebear)	Weight
FU-5L-9	42	59	21	50 Pitch × 17 = 850	25	200 Pitch × 4 = 800	50	10- Ø 4.5	10.8	10.2	900	51	C-5L (Qty.: 18)	1.8kg
FU-P5L-9						200 Pitch × 8 = 1,600					1,800		P-5L (Qty.: 18)	1.6kg
FU-5L-18				50 Pitch × 35 = 1,750		1,800	C-5L (Qty.: 36)	3.4kg						
FU-P5L-18				200 Pitch × 8 = 1,600		1,800	P-5L (Qty.: 36)	2.9kg						

You can choose the stainless steel freebears to mount according to the intended use.

Freebear Unit

RoHS CAD 3D

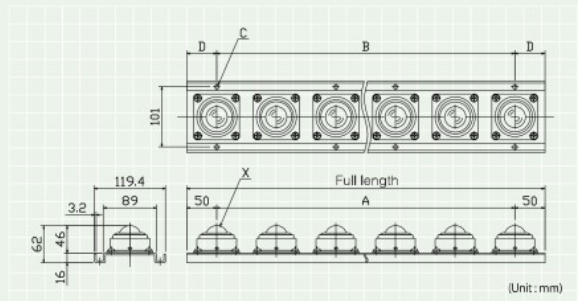

Model	A	B	C	D	Full length	X (Freebear)	Weight
FU-12K-9	100 Pitch × 8 = 800	200 Pitch × 4 = 800	10- Ø 7	50	900	C-12K (Qty.: 9)	8.2kg
FU-P12K-9						P-12K (Qty.: 9)	6.6kg
FU-12K-18	100 Pitch × 17 = 1,700	200 Pitch × 8 = 1,600	18- Ø 7	100	1,800	C-12K (Qty.: 18)	16.4kg
FU-P12K-18						P-12K (Qty.: 18)	13.1kg

You can choose the stainless steel freebears to mount according to the intended use.

※Product specifications are subject to change without prior notice. Please contact us for details.